

# Instrumentation-The Link Between Theory and Practice in Geotechnical Engineering

An homage to Ralph B. Peck

Based on the paper "Field Instrumentation-The Link Between Theory and Practice in Geotechnical Engineering", Presented at the Seventh International Conference on Case Histories in Geotechnical Engineering in Chicago, USA, April 2013

by  
Elmo DiBiagio

## FOREWORD

The seventh International Conference on Case Histories in Geotechnical Engineering in Chicago in April 2013 held a special session to commemorate the Legacy of Professor Ralph B. Peck. I was one of the six invited lecturers. The invitation was of course a special honor for me as I was one of Professor Peck's PhD students. The recipient of the honor is not only me but also NGI and the entire NGI Family.

Through his teachings, publications and his personal contact, Professor Ralph B. Peck has had a unique influence on the professional careers of many students and geotechnical engineers worldwide. Ralph Peck had a close association with NGI dating back to 1953 when he met for the first time Laurits Bjerrum, NGI's first Director. Ralph Peck's interest and respect for NGI is manifested by his donating his professional papers to NGI which led to the historical library in his name at NGI. I wish to recall the key role that Professor Peck played in my own professional career and the events that led to my becoming part of NGI's family and being invited to give the Chicago lecture in recognition of his achievements.

In 1955, I spent one year at NGI on a Fulbright fellowship. At the request of NGI, I came back to Oslo in 1958 for two years, to assist with the instrumentation of deep excavations for buildings and the new subway in Oslo. I met Ralph for the first time in Norway in October 1959. He had been engaged by the City of Oslo to review the work on the new subway. I was asked to show some of the instrumented excavations to Ralph. The city of Oslo provided us with a chauffeur and a comfortable car. It was a long day. At the end of the day, Ralph looked at me and said, "If you want to pursue a PhD send me a postcard". In 1962, I sent him a formal letter instead of a postcard! He became my PhD adviser at the University of Illinois. Although my prior professional experience was related to instrumentation and four years teaching Engineering Physics, I wanted to try something different. Therefore, I elected numerical modeling of an open cut excavation as my thesis topic. When the thesis was approved, Ralph politely reminded me that: "No theory or mathematical model can be considered satisfactory until it has been checked by actual observations"! That statement convinced me to concentrate my career on field instrumentation. At the same time, Laurits Bjerrum had asked me if I would be interested in assisting setting-up an instrumentation division at NGI. I accepted, returned to NGI in 1965 and have worked with field instrumentation ever since.

Since I was one of Ralph's students, the case histories in the paper in his honor are presented as "One-page Summaries", a report form that Ralph insisted on in his course CE 484 on Case Histories at the University of Illinois. In Chicago, I presented 22 case histories. In this publication, there are 24 case histories, arranged chronologically. They reflect, to a degree, the evolution in applications, technology and complexity of NGI's geotechnical and structural instrumentation projects over the past 60 years.

I close this Preface with an important lesson I learned while preparing the One-page Summaries. Much to my surprise, it took considerably longer to prepare the summaries than I had anticipated, even with the help from colleagues. The main reason was the time required to find old drawings, photographs and other details for projects carried out decades ago - even though I had been actively involved in many of the projects. The lesson learned is that every NGI project should be summarized in the form of a simple *One-page Summary*. We should not wait many years to do so. Compiling a one-page summary is a simple task if it is prepared immediately after the project has been completed.

Elmo DiBiagio

Oslo, 2013-11-30

**An homage to Ralph B. Peck**  
**INSTRUMENTATION-THE LINK BETWEEN THEORY AND PRACTICE**  
**IN GEOTECHNICAL ENGINEERING**

Elmo DiBiagio  
Norwegian Geotechnical Institute (NGI), Oslo, Norway

## INTRODUCTION

This publication is based on the paper *Field Instrumentation – The Link Between Theory and Practice in Geotechnical Engineering*, which was prepared by the author for the Seventh International Conference on Case Histories in Geotechnical Engineering in April 2013. The Conference held a special session to commemorate the Legacy of Ralph B. Peck. This publication pays homage to Professor Ralph B. Peck, a close friend and professional associate of the NGI ever since its start in 1953.

Professor Ralph B. Peck, the father of the *Observational Method* in geotechnical engineering, recognized early the importance of field instrumentation and performance monitoring in geotechnical engineering, and he did a lot to promote its use. Thus, the author felt it appropriate to illustrate the importance and diversity of field instrumentation projects through selected case histories from the files of the NGI. The examples include retaining structures, braced excavations, slurry trench excavations, large scale tests, dams, glaciers, avalanches and offshore structures. For each case cited the principal scientific, practical, and economic benefits of the monitoring program are pointed out.

Geotechnical engineers work in two worlds: a theoretical world where ideas and events can be represented by numbers and calculated to many decimal points, and a practical world where observations and events can only be described in qualitative terms. The case histories presented at the six previous University of Missouri conferences have given geotechnical engineers a much better understanding of the practical world of geotechnical engineering. The selection of a topic for my lecture honoring the legacy of Ralph Peck was not difficult. Professor Ralph B. Peck, the father of the Observational Method in geotechnical engineering, and a firm believer in field instrumentation as a geotechnical tool, relied extensively on case histories to teach his students how to find solutions and learn from practice. It was therefore appropriate to focus my lecture on some of NGI's case histories of field instrumentation.

## ONE-PAGE SUMMARIES

The manner in which the case histories are presented can be attributed to Ralph B. Peck who was a true master in the art of communication. He was himself a great communicator. His communication style was always clear-cut, concise and to the point. The need for simplicity in communication is a philosophy that he passed on to, and demanded of, his students. For example, in his course CE 484 on Case Histories at the University of Illinois, Professor Ralph B. Peck required that the summary reports prepared by his students not be more than one page long. He justified this requirement by saying, "If you cannot reduce a difficult engineering problem to just one sheet of 8-1/2 x 11-inch paper, you will probably never understand it"! Since the author of this paper was one of his students, the examples printed in this paper will be presented in exactly that form: *One-page Summaries*.

This paper is a collection of *One-page Summaries* of instrumentation case histories from selected NGI projects. They are arranged chronologically and reflect, to a degree, the evolution in applications, technology and complexity that has occurred in geotechnical instrumentation projects in the past 60 years at NGI.

## THE IMPORTANCE OF MEASUREMENT

*"When you measure what you are speaking about and express it in numbers, you know something about it, but when you cannot express it in numbers your knowledge about it is of a meagre and unsatisfactory kind."*

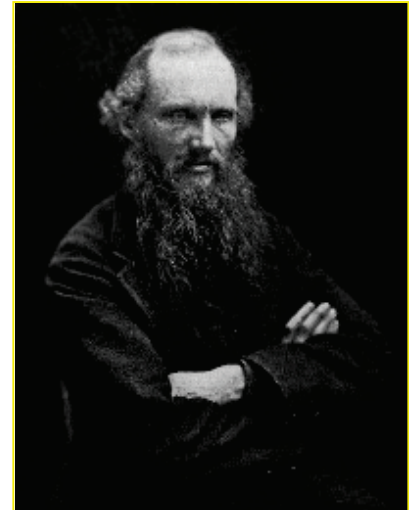

*Lord Kelvin (1824–1907).*

The result of visual observation is qualitative information. The end product of instrumentation is quantitative information. When these two sources of information are combined in a performance monitoring program, they provide the geotechnical engineer with a powerful tool. A tool that has a potential for many scientific and economical returns, provided, of course, that the relevant observations are made and the appropriate measurements are taken with the level of accuracy required.

Performance monitoring is not a new idea. Geotechnical engineers have traditionally relied heavily on field measurements for research, to find solutions to problems on hand, or to advance the state-of-the-art. Technological advances in other fields of science have resulted in many significant improvements in instruments and measurement techniques. Consequently, it has become more common to implement performance monitoring programs. It has also become a substantial scientific and commercial activity.

Although our ability to make measurements and record and process data has improved considerably, fundamental information needed to plan and carry out the details of an instrumentation program is not readily available to users of instrumentation. To provide help and insight into the "how, when, where and why" of field measurement programs, 24 case histories from NGI files are briefly summarized in the remainder of the article.

### INSTRUMENTATION CASE HISTORIES

The case histories were selected to illustrate a variety of applications of performance monitoring programs, how they were carried out and what the principal benefits have been. The paper presents 24 cases, divided into 4 main categories, namely,

- Construction control (5),
- Large scale or full scale tests (10),
- Structural monitoring/Performance monitoring (5),
- Research to advance the state-of-the-art (4).

The numbers in parentheses indicate how many case histories belong to each category. For each example, a brief description is given of the relevant design or construction problems for each project, and the function of the instrumentation in relation to these problems is pointed out. The types of measurements made are given, and an attempt is made to show how instrumentation was used to solve or provide a better understanding of the actual problems.

Each case history was intentionally limited to Ralph B. Peck's *One-page Summaries*. It was no easier for the author to do that now than when he was one of Peck's students at University of Illinois! Some of the case studies are so extensive and complicated that even Professor Peck probably would have had trouble presenting them as *One-page Summaries*! Obviously, the summaries do not contain all the details

that are important to instrumentation projects. However, complementary information can be found in the references provided. The case histories are listed in the table below:

No.	Title of Case History	Year	Page
1	Forces in a braced trench in weather marine clay	1955	4
2	Deep excavation stabilized by filling it with water	1959	5
3	In situ shear tests, 1-m in diameter, to depths of 12 m	1967	6
4	Unexpected leakage at an embankment dam	1968	7
5	A rockfill dam with a bitumen-gravel core	1969	8
6	Full scale test of a 28-m deep slurry trench in soft clay	1970	9
7	A stable test embankment with a factor of safety of 0.57	1972	10
8	A retaining structure for storing granular material	1973	11
9	Settlement of a 130- ton gravity anchor in 460-m of water	1974	12
10	A 129-m high rockfill dam with sloping moraine core	1979	13
11	Contact pressure at ice-bedrock interface under a glacier	1980	14
12	Monitoring a 800,000 ton offshore gravity base structure	1981	15
13	Monitoring dynamic parameters in a snow avalanche	1982	16
14	Offshore penetration test of a 23- high concrete panel	1985	17
15	A 90-m high rockfill dam with an asphaltic concrete core	1987	18
16	Model test of a suction anchor in soft clay	1989	19
17	Measurement of stresses in subsea pipelines	1995	20
18	Ormen Lange Piezometers	2001	21
19	An early warning system (EWS) for detecting rock falls	2003	22
20	Observational method applied to a large tailings dam	2007	23
21	Fibre-optic monitoring a 950-m long steel girder bridge	2008	24
22	Model test of a drop anchor in 330-m of water	2008	25
23	Pre-piling for offshore wind turbines	2009	26
24	Heave and negative pore pressure in swelling clay	2010	27
	References		28

I am one of many engineers who have had the opportunity to meet Professor Ralph B. Peck. For one half-century, our mutual interest in instrumentation and the Observational method has created a unique bond of personal and professional friendship between Professor Peck and me.



*Ralph B. Peck and Elmo Dibiagio in Peck Library at NGI, June 2000.*

Oslo, 2013-11-13

## Example 1 (1955) - Measurement of strut load in a test trench excavated in stiff marine clay

CATEGORY	MAIN OBJECTIVE	MAIN BENEFIT
Full scale test	Compare measured strut loads to calculated values	Design calculations verified

### BACKGROUND AND DESCRIPTION OF PROJECT

The usual soil profile in Norway consists of from 2 to 6 m of heavily fissured weathered crust at the top ranging from 2 to 6 m in thickness. Since numerous excavated trenches are required for installation of underground water lines and other utilities, NGI initiated in 1955 a full scale field test in order to get a better understanding of the stability of trenches excavated in fissured clay. This was the first field instrumentation project undertaken by the Institute.

### FACTORS THAT INFLUENCED THE DESIGN OF THE MONITORING PROGRAM

Figure 1 shows a plan and section of the excavation. The main test section, in which the measurements were taken, was 14 m long, 09 m wide and 4 m deep. One end of the trench sloped upwards to the surface, the other opened into a larger excavation, 5 m deep, composed of one vertical side and four others, each having different slopes. This section served both as a drainage sump and enabled a visual comparison of how resistant the different slopes were to weathering.

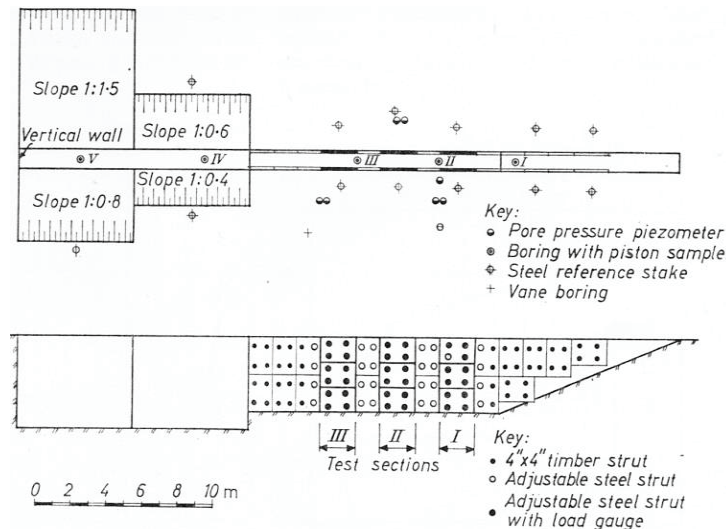

Fig. 1. Plan and section of test excavation

### SCOPE OF INSTRUMENTATION

Each of the three measuring sections within the trench was 2 m wide and had 2 vertical rows of adjustable steel struts fitted with vibrating-wire type load cells. There were 6 levels of struts. Special steel reference stakes and benchmarks were placed in and around the excavation to record horizontal and vertical deformations of the soil mass. Thirteen open standpipe piezometers were installed to measure changes in pore water pressures, three of these were placed 17 m from the excavation to serve as a control.

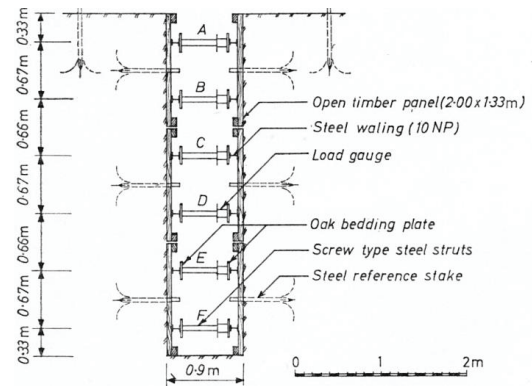

Fig. 2. Cross-section of trench

### MOST SIGNIFICANT INFORMATION DERIVED

In general, the strut loads increased gradually after the first measurements were taken. After each period of rainfall there was a sharp increase in the total earth pressure, then the total earth pressure remained nearly constant for a short interval. Thereafter, a characteristic decrease occurred until another interval of rainfall caused the whole cycle to be repeated again. As the temperature started to drop below freezing, the immediate effect on the magnitude and distribution of the strut loads was quite surprising. Freezing of the clay at the surface of the ground and within the trench resulted in a marked reduction in loads carried by the upper A and B level struts and an enormous increase in the forces transmitted to the lower struts. Figure 3 shows the distribution of the maximum averaged strut loads recorded together with a curve denoting the limit of frost penetration.

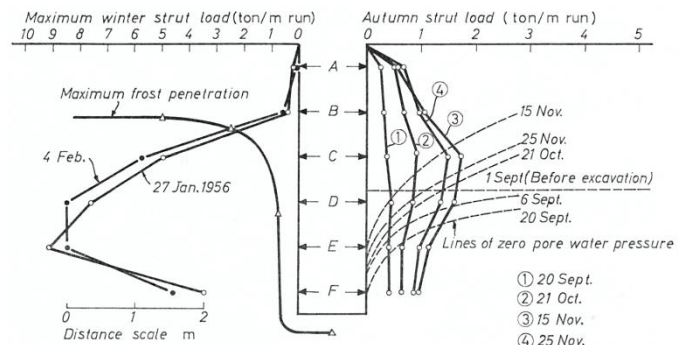

Fig. 3. Summary of measurements during autumn and winter

The computed maximum total earth pressure, based on an effective stress analysis with the assumption that  $c' = 0$ , was in good agreement with measured values. Peck's rule for calculating the total earth pressure was also valid.

REFERENCE: E. DiBiagio and L. Bjerrum (1957)

## Example 2 (1959) - Braced sheet piled excavation in soft clay

CATEGORY	MAIN OBJECTIVE	MAIN BENEFIT
Construction control	Monitor safety of a difficult excavation	Reduced cost and construction time

### BACKGROUND AND DESCRIPTION OF PROJECT

In 1959 an open cut excavation 30 m by 11 m and 11.5 m deep in soft clay was required to install compressed air locks needed to start driving a new subway tunnel in Oslo. The design depth of the required excavation exceeded the critical depth. Because of the large depth to bedrock at the site it was not feasible to improve the stability of the excavation by driving sheet piles to bedrock. Thus, a special construction procedure had to be used to allow excavation to full depth without causing a bottom heave failure.

To avoid a bottom heave failure the excavation was stabilized by flooding it with water before the final 5.7 m was excavated. The design called for 4 levels of bracing, one of which was to be installed underwater by divers, Figure 1.

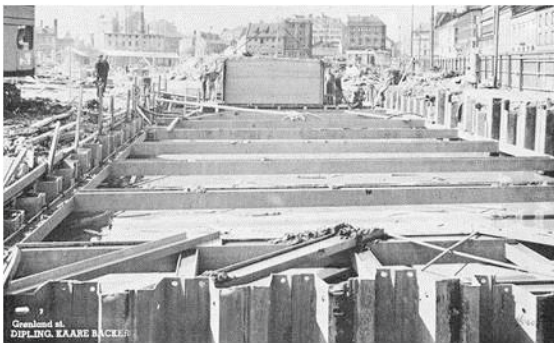

Fig. 1. Excavation after it was filled with water

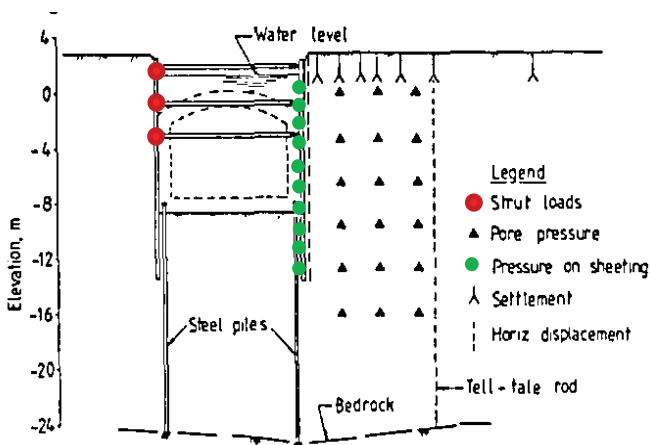

Fig. 2. Main instrumented cross section

### FACTORS THAT INFLUENCED THE DESIGN OF THE MONITORING PROGRAM

In view of the complexity of this excavation and because of the need to verify that the design was safe and sound, an extensive monitoring program was justified. It was felt that instability of the excavation could be assessed primarily by careful study of ground movements and strut loads, providing these were

measured frequently and accurately enough to be able to look at not only magnitudes but also rates of change in the data during critical stages of the work.

### SCOPE OF INSTRUMENTATION

The primary instrumentation included 9 load cells, 18 settlement reference points, one heave gauge and two inclinometer casings to provide convenient and accurate measurements of strut loads and ground movements. Other instruments included 23 earth pressure cells, 8 pore pressure sensors on the sheet piles, and 19 piezometers in the natural ground. These provided supplementary information.

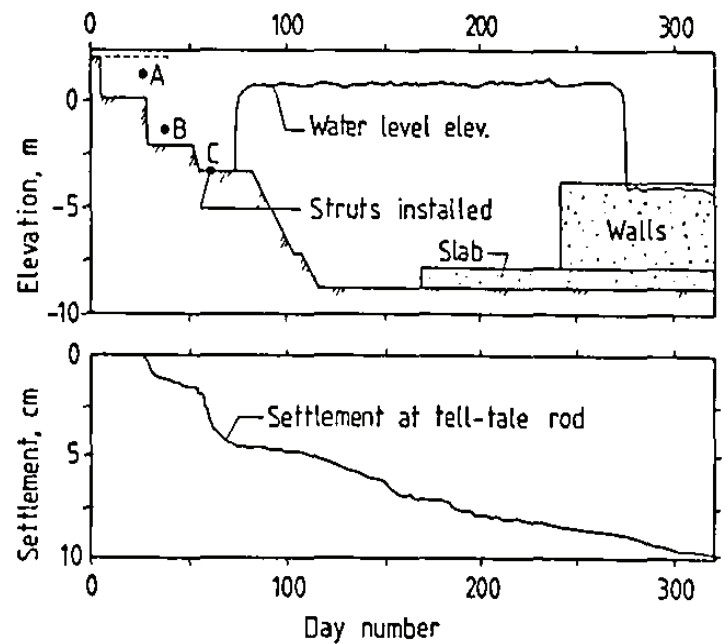

Fig. 3. Construction schedule and measured settlement

### MOST SIGNIFICANT INFORMATION DERIVED

The stabilizing effect of the water on the excavation was clearly shown in the measured rates of settlement and the measured strut loads. As work continued, an analysis of the field measurements indicated that excavation could proceed to the final depth without installation of the fourth level of struts, and this was done.

- The field measurements confirmed adequate safety of the project while the work was in progress, and the work was completed without mishap.
- The measurement program contributed to a significant savings in time and money because the underwater bracing was found unnecessary.

REFERENCE: DiBiagio and Kjærnsli (1961)

## Example 3 (1967) - Large diameter in situ direct shear tests in soft clay

CATEGORY	MAIN OBJECTIVE	MAIN BENEFIT
Basic research	Compare in situ shear tests to field vane and lab tests	Improved knowledge of shear strength

### BACKGROUND AND DESCRIPTION OF PROJECT

Ever since it was founded in 1953 the Norwegian Geotechnical Institute has devoted considerable research effort, both in the field and in the laboratory, on the shear strength of the soft marine clay deposits commonly found in Norway. The desire to both supplement and verify the findings obtained from laboratory tests and the field vane ultimately resulted in the construction of an unusual piece of research equipment for carrying out large-scale in situ direct shear tests, Figure 1.



Fig.1 In situ shear device on location

The apparatus was in reality a gigantic self-boring sampling tube that trimmed out a vertical core of undisturbed clay, one meter in diameter, as it burrowed into the ground. When a shear test was desired the boring process could be stopped and the clay core within the device sheared in simple undrained shear. Tests could be carried out down to a depth of 12 m. Field tests were performed at 5 sites in Norway and Sweden.

The principal features of the device are shown on Figure 2. The device consists of three main sections: a boring head, a “shear box” and a series of extension cylinders. The function of the boring head is to trim out a cylindrical core of undisturbed clay and to remove the material around the periphery of the apparatus to form an annular space. As the device penetrates into the ground, the clay directly below the protruding section of the boring head is forced through the perforated screen into the mixing chamber. In the mixing chamber the clay is reduced to slurry under the combined action of high pressure water jets and 21 mechanical agitators which are equally spaced around the mixing chamber. The agitators are activated by a sprocket chain driven by a hydraulic motor. The clay slurry is removed by suction pumps and the annular space above the boring head between the apparatus and the sides of the bore hole is filled with water to stabilize the hole.

The two halves of the shear box are clamped together during boring operations. When these clamps are released the upper half of the shear box can be translated, up to 5 cm, relative to

the bottom half and in the process the clay core inside is sheared on a horizontal plane.

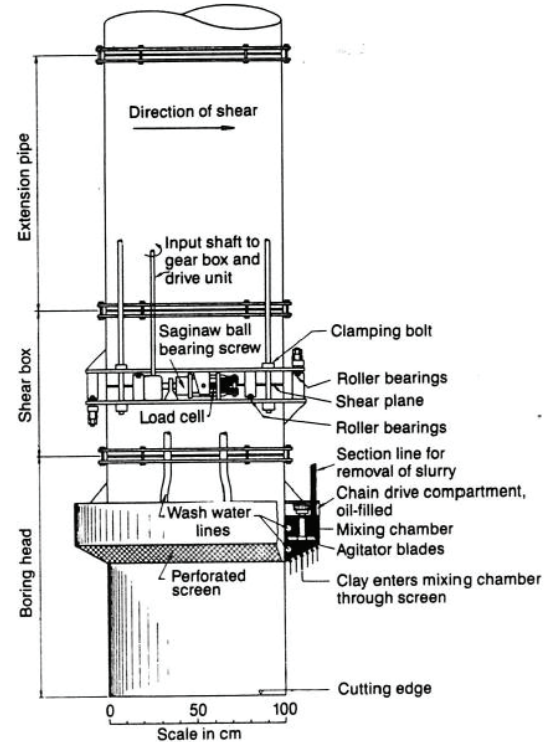
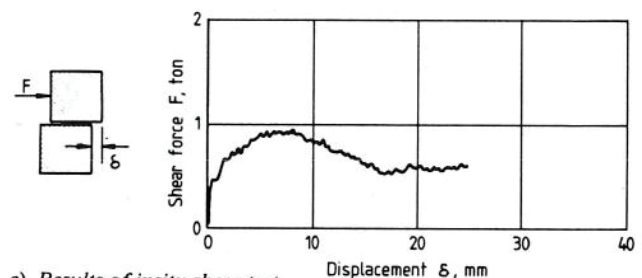

Fig.2. Details of the shear apparatus

### SCOPE OF INSTRUMENTATION

The force necessary to shear the clay core is developed by mechanical means and controlled from the surface. The shear force and displacement are monitored by specially designed instruments mounted on the shear box. Other instruments are used to measure verticality of the apparatus and the normal force on the top part of the shear box.

### TYPICAL EXAMPLE OF SHEAR TEST



c) Results of in situ shear test

Fig. 3. Typical result of a direct shear test

REFERENCE: DiBiagio and Aas (1967).

## Example 4 (1968) - Leakage during first filling of reservoir at an embankment dam

CATEGORY	MAIN OBJECTIVE	MAIN BENEFIT
Performance monitoring	Evaluate the nature and extent of problem	Correct remedial action was taken

### BACKGROUND AND DESCRIPTION OF PROJECT

Some monitoring programs are strictly problem oriented and are not initiated until construction problems arise or unsatisfactory performance has been observed. In these cases instrumentation can be useful in assessing the nature and extent of the problem, to plan corrective action<sup>1</sup> or to evaluate the effectiveness of remedial actions taken.

Muravatn Dam is a 77 m high rockfill dam founded directly on bedrock with a central impervious core of moraine till. It was completed in 1968. An unlined headrace tunnel passes directly underneath the dam as shown in Figure 1.

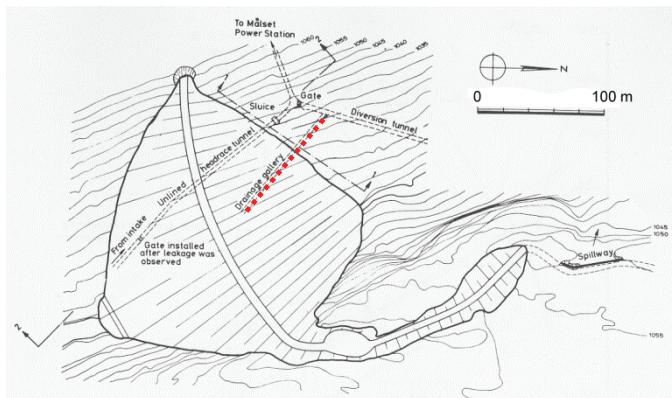

Fig. 1. Dam site with location of tunnels

The bedrock consists of foliated and banded gneiss which in itself is of high quality and can be regarded as impermeable. In such a case stability and leakage problems are mainly dependent on fault zones and joints. The geological investigations performed prior to the design of the dam did not indicate any unusual conditions or leakage problems. Thus no special precautions were taken in the design of the dam, and no special instrumentation was felt necessary. The original monitoring program for the dam and foundation included only one weir station and 68 surface monuments for measurement of leakage and surface displacements.

### FACTORS THAT INFLUENCED THE DESIGN OF THE MONITORING PROGRAM

When water was impounded in the reservoir for the first time, a significant leakage of water into an adit shaft downstream of the dam was observed. The leakage rate fluctuated with the water level in the reservoir. Additional geologic mapping revealed a previously undetected fault zone, 1 to 3 m thick, consisting of highly jointed rock which ran underneath the dam and outcropped upstream of the dam in the reservoir area.

The effect of the leakage through the fault zone on the safety of the dam became a matter of concern because of the unlined pressure tunnel directly beneath the dam, and the location of the fault zone was unfavorable to the stability of the downstream foundation. To properly assess the situation and to plan corrective action, it was necessary to know the water pressure in the fault zone and in the dam foundation.

### SCOPE OF INSTRUMENTATION

Nine piezometers were installed at different depths in a net of boreholes close to the toe of the dam to monitor water pressure in the foundation.

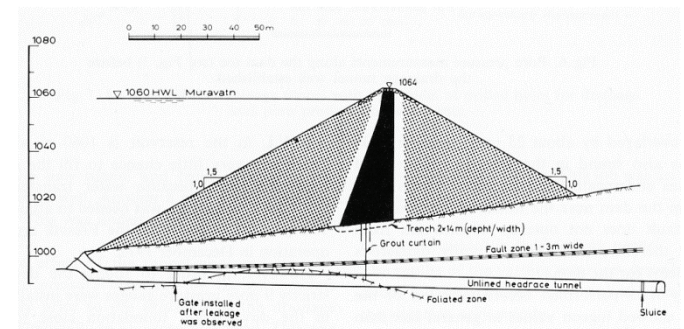

Fig. 2. Cross section of dam

### MOST SIGNIFICANT INFORMATION

The piezometer measurements showed that the pore pressure was alarmingly high compared to the water level in the reservoir. It was obvious that something had to be done to reduce this pressure. To control and relieve the high pressure, a drainage gallery was driven into the down stream foundation and a system of drainage holes and observation holes were drilled from the gallery. Pressure sensors were connected to packers installed in eight of the observation holes to continuously monitor pore pressure in order to evaluate the effectiveness of the drainage system.

### BENEFITS OF THE MONITORING PROGRAM

A need for corrective action was confirmed by the measurements of high water pressure in the dam foundation. To control and relieve the pressure, a drainage gallery was driven into the downstream foundation and a system of drainage holes and observation holes were drilled from the tunnel. Measurements showed the drainage system to be quite effective, and the high pore pressures in the foundation at the toe of the dam dropped radically and to an acceptable value and have remained so ever since.

REFERENCE: Nilsen and Lien (1976)

## Example 5 (1969) - Rockfill dam with a core of coarse gravel and bitumen

CATEGORY	MAIN OBJECTIVE	MAIN BENEFIT
Construction control	Verify new design concept for impervious core	Design verified

### BACKGROUND AND DESCRIPTION OF PROJECT

A 12 m high, 120 m long trial rockfill dam was constructed in 1969 with a unique central watertight membrane. This 0.5 m wide barrier was formed in 0.2 m thick layers by filling the voids of a matrix of prepacked rock aggregate with hot bitumen. A cross section of the dam is shown in Figure 1.

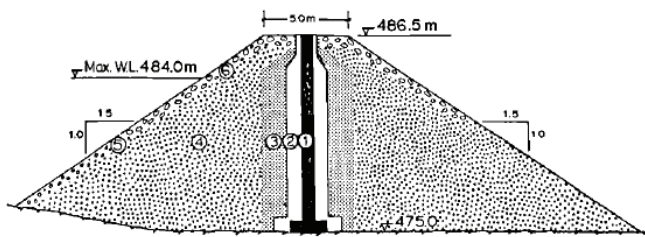

Fig. 1. Cross section of the trial dam

Zone 1: Aggregate: 3/4 - 3 inch gravel, voids filled with hot bitumen  
 Zone 2: Filter: <3/4 inch Tunnel spoil  
 Zone 3 Transition



Fig. 2. Injecting hot bitumen into gravel matrix

### FACTORS THAT INFLUENCED THE DESIGN OF THE MONITORING PROGRAM

In order to prevent the impounded water from "fingering" through the bitumen membrane, the pressure in the bitumen must be higher than the water pressure at a corresponding level in the reservoir. To achieve this, the membrane extended above maximum pool elevation, thus creating an overpressure in the bitumen relative to the reservoir water pressure. The primary objective of the measurement program was to measure the distribution of bitumen pressure with depth so that it could be compared with the external water pressure. In addition it was considered important to monitor horizontal deformations of the membrane since it was constructed of a viscous material.

### SCOPE OF INSTRUMENTATION

The instrumentation consisted of survey monuments, six special pressure transducers for measuring the fluid pressure in the bitumen, and extensometers at three levels to measure change in width of the membrane.

A piezometer that could be used to measure pore-bitumen pressure had to be developed and tested. This was done by replacing the filter of a standard vibrating-wire piezometer with a piece of coarse wire mesh and saturating the void between the mesh and the sensing membrane with bitumen just as one saturates an ordinary piezometer for measuring pore water pressure. Laboratory tests showed that the piezometers worked very well.

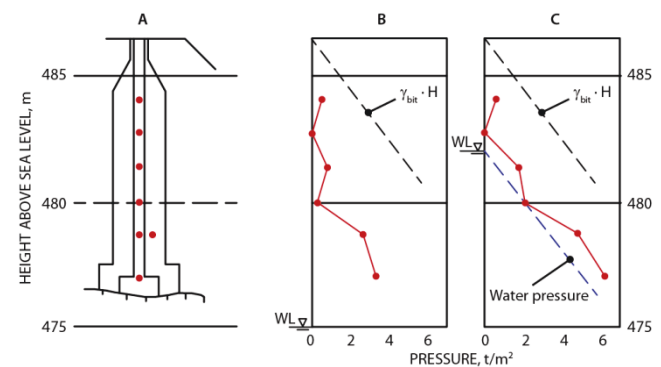

Fig. 2. (A): Location of pressure sensors in core and filter  
 (B): Bitumen pressure: No water in reservoir  
 (C): Bitumen pressure: Water level at Elev. 480 m

### MOST SIGNIFICANT INFORMATION DERIVED FROM THE MONITORING PROGRAM

Measurements were continued on a regular basis for three years after completion of the dam. The measured change in width of the core was very small, of the order of millimeters. The distribution of bitumen pressure with depth was less than hydrostatic with respect to the top of the bitumen, but the pressure measured at the various levels was always slightly higher than the reservoir water pressure at the same depth.

- Satisfactory performance of the new type of membrane was verified.
- The measurements and experience obtained on this dam provided a basis for the design and construction of five other small dams of this type.

REFERENCE: Reference: Kjærnsli and Sande (1973)

## Example 6 (1972) - Trial embankment on soft sensitive clay

CATEGORY	MAIN OBJECTIVE	MAIN BENEFIT
Basic research	Cause a deliberate failure to study strength of clay	Better understand of shear strength

### BACKGROUND AND DESCRIPTION OF PROJECT

In 1972 a trial embankment of sand, 6.25 m high, 22 m wide and 70 m long was constructed on a very soft deposit of clay with high sensitivity and low plasticity. The objective of the test was to cause a bearing capacity failure to study the anisotropy of the foundation soil and not specifically to study the embankment. Of primary concern was the need to verify that the field vane test underestimates undrained shear strength of soils with low plasticity.

The upper 4 m of the clay was stiff weathered dry crust. To minimize the effect of this layer on the test results, 3 narrow trenches were excavated to a depth of 4 m in zones where it was assumed the failure plane would occur. The trenches were backfilled with bark.

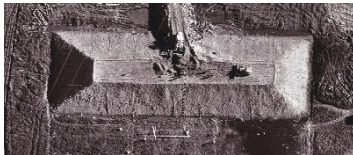

Fig. 1. Aerial view of test fill at maximum height

### FACTORS THAT INFLUENCED THE DESIGN OF THE MONITORING PROGRAM

Measurements of deformations and pore pressure are fundamental to an understanding of the performance of an embankment on soft ground. Because of the low plasticity of the soil a brittle failure was anticipated. It was important to have piezometers that could be observed rapidly. Thus, electrical piezometers were preferred. Finite element computations were used to locate the zones of initial yield beneath the embankment to optimize the locations of the piezometers and deep settlement reference points.

### SCOPE OF INSTRUMENTATION

The instrumentation comprised: 30 electrical piezometers; 17 open standpipe piezometers; 17 surface survey monuments; 30 deep settlement reference points; 6 vertical inclinometer casings; and brittle wooden sticks to aid in locating the failure plane, Figure 2.

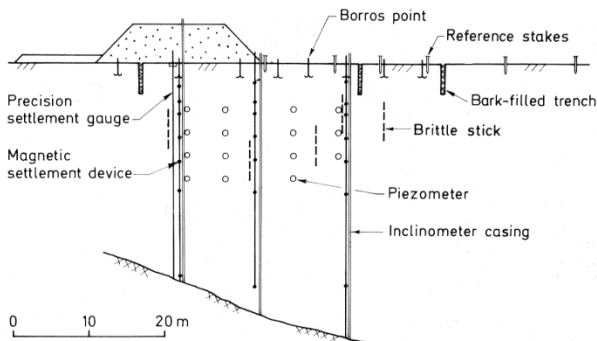

Fig. 2. Cross section of the instrumented test fill

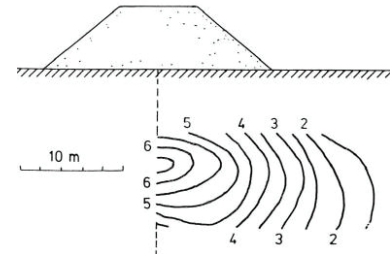

Fig. 3. Measured change in pore pressure at maximum height of fill,  $t/m^2$

### MOST SIGNIFICANT INFORMATION DERIVED FROM THE MONITORING PROGRAM

The most significant observation was that the embankment did not fail at a height of 3.5 m as predicted on the basis of field vane strength data. Even at a maximum height of 6.25 m and a computed safety factor of 0.57 the embankment was stable for a two year period before it was intentionally brought to failure by excavating a 7 m deep water-filled trench parallel to the embankment. The field measurements helped explain why.



Fig. 4. Photograph after failure

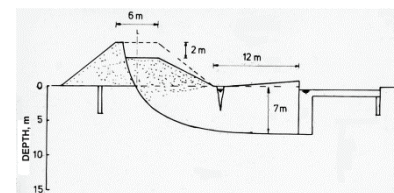

Fig. 5. Cross section after failure

### BENEFITS FROM THE MONITORING PROGRAM

- The test confirmed that field vane strength data could not be used directly in the stability analysis.
- Anisotropic behaviour of the clay was confirmed.
- Back computations based on the observed failure plane and anisotropic strength data derived from laboratory direct shear tests and triaxial active and passive tests gave realistic results.

REFERENCE: DiBiagio and Stenhamar (1975)

## Example 7 (1970) - Stability of a deep slurry trench in soft clay

CATEGORY	MAIN OBJECTIVE	MAIN BENEFIT
Full scale test	Investigate use of slurry trench in soft clay	Design verified

### BACKGROUND AND DESCRIPTION OF PROJECT

A full scale experimental slurry trench, 1 m wide, 5 m long and 28 m deep was excavated in soft marine clay and instrumented in 1970 to test this method of construction for a proposed combined rail and subway tunnel, one over the other.

### FACTORS THAT INFLUENCED THE DESIGN OF THE MONITORING PROGRAM

Information was lacking on this topic. Prior to 1969 there had been no applications of the diaphragm wall method for constructing in situ walls in Norway. Thus, little thought had been given to the special problems that might arise with the use of this method in soft clay. The literature contained very little about the use of slurry trenches in soft ground.

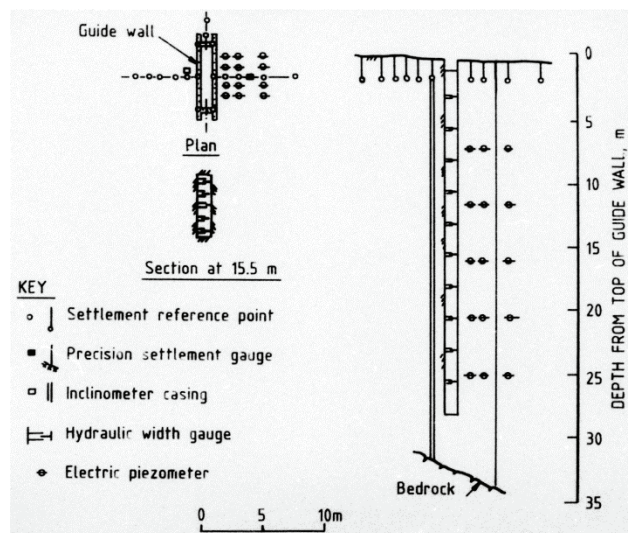

Fig. 1. Details of the slurry trench excavation

The primary objectives of the test excavation were (1) to establish whether it was feasible or even possible to excavate a slurry trench to a depth of 28 m in soft clay and (2) to evaluate the stability of the trench as a function of the density of the slurry and the length of time that the trench is kept open.

### SCOPE OF INSTRUMENTATION

Accurate measurements of ground movements were considered to be most important, in particular measurements of the inward creep movements of the walls of the trench as a function of time and the density of the slurry. The instrumentation consisted of 23 settlement reference points, one inclinometer casing, 14 extensometers for monitoring inward movement of the walls of the trench, and 15 vibrating-wire piezometers.

The trench was excavated using a bentonite slurry with a specific

gravity of 1.24 and observed for a total of 31 days. During this interval the specific gravity of the slurry was reduced in two stages from 1.24 to 1.10 and from 1.10 to 1.00 (plain water).

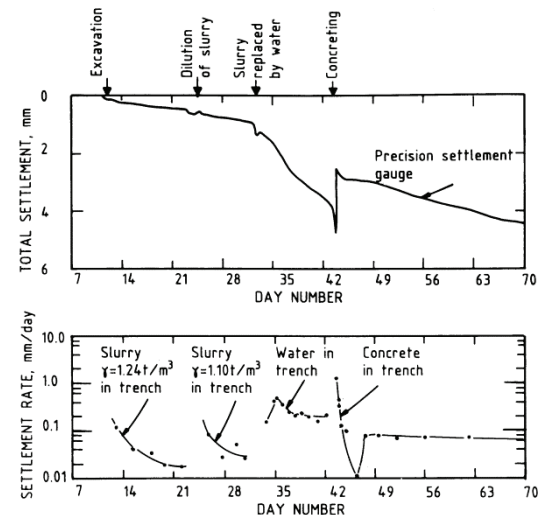

Fig. 2. Measured magnitude and rate of settlement

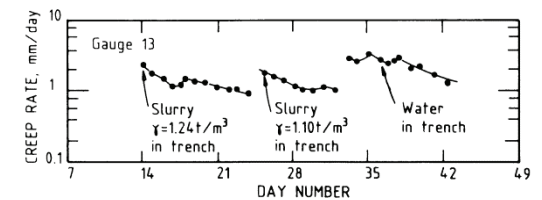

Fig. 3. Inward creep of the walls of the trench.

### MOST SIGNIFICANT INFORMATION DERIVED

The most important observations were the deformation measurements. Typical results are shown in Figures 2 and 3. Because of the precision in the measurements, it was possible to determine creep rates for settlement and inward movement of the walls of the trench as a function of time and density of the slurry. On the basis of the deformation measurements, in particular the creep data, it was judged that bentonite slurry was not necessary, and the trenches could be excavated to the required depth with plain water as the supporting fluid.

One very practical consequence that the test had on the combined rail-subway tunnel was that it was the basis for deciding to use water in trenches for the longitudinal walls of the tunnel. This resulted in a very substantial savings compared to the use of bentonite slurry. The measurements contributed to development of a new method for evaluating the stability of slurry trenches.

REFERENCE: DiBiagio and Myrvoll (1972)

## Example 8 (1973) - Concrete retaining structure for bulk storage of granular material

CATEGORY	MAIN OBJECTIVE	MAIN BENEFIT
Full scale test	Optimize design of a retaining structure	Design verified

### BACKGROUND AND DESCRIPTION OF PROJECT

Large scale field tests and large models generally require extensive amounts of instrumentation. One common application is to validate new design or construction concepts before they are put into general use. This example illustrates a full scale test that was carried out to optimize the design of a retaining structure.

A number of concrete retaining structures were to be constructed for bulk storage of artificial fertilizer. A full scale test was carried out on the first one to verify the design and to optimize it for future applications. This storage bin was rectangular in shape and was constructed of free standing "L"-shaped concrete wall elements, 5.4 m high and 3 m wide at the base as shown in Figure 1.

### FACTORS THAT INFLUENCED THE DESIGN OF THE MONITORING PROGRAM

The main uncertainty in the design was the estimation of the pressure on the wall and base as a function of height and slope angle of the granular fertilizer.

The resistance of the retaining wall to sliding and overturning depends on the magnitude and point of application of the horizontal and vertical forces on the wall. Direct measurement of these forces was not feasible. Instead it was decided to use pressure transducers to measure the pressures on the wall and compute the forces from the data. To provide a check measurement and to verify the stress in the reinforcing steel, strain gauges were used to monitor stress in the reinforcing at the base of the wall where the maximum moment was expected.

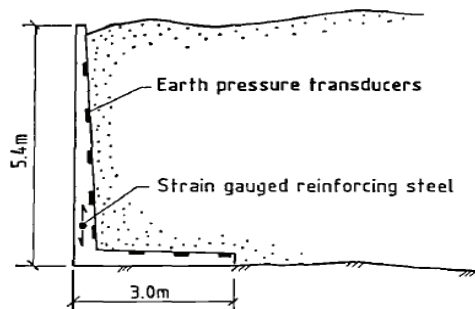

Fig. 1. Cross section of instrumented storage facility

### SCOPE OF INSTRUMENTATION

Five pressure transducers were flush mounted on the vertical face of the retaining wall. Three were mounted on the base of the "L"-shaped element to measure the vertical pressure developed between the fertilizer and the base.

One reinforcing steel bar was strain-gauged to provide a check on the maximum bending moment in the retaining wall.

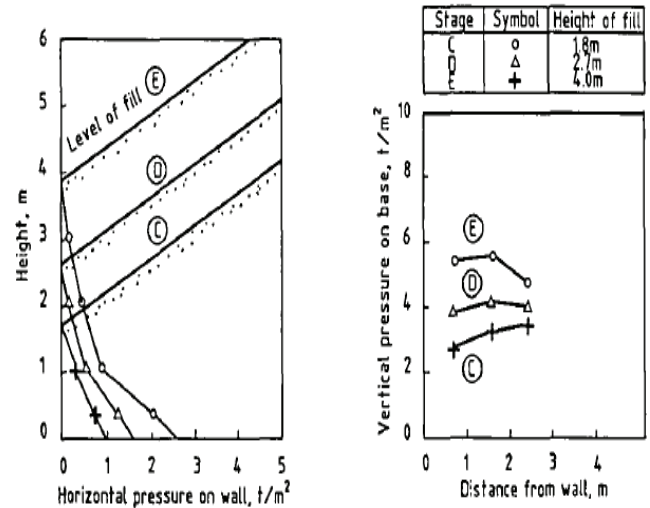

Fig. 2. Measured pressure distribution on wall and base.

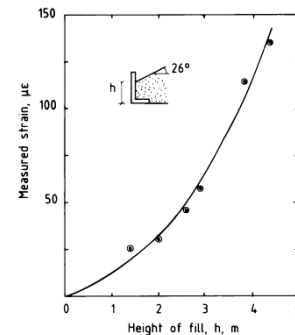

Fig.3. Measured strain in reinforcing steel

### MOST SIGNIFICANT INFORMATION DERIVED FROM THE MONITORING PROGRAM

- The method of filling the storage bin was found to be important.
- For small heights of fill the pressure distribution on the retaining wall was found to be approximately linear but it became more nonlinear as the height of the fill increased, Figure 2.
- The total horizontal force on the wall agreed with the value predicted using classical earth pressure theory, but the distribution of pressure did not.
- The vertical pressure on the base was found to be approximately equal to the overburden pressure.
- The observed stress in the reinforcing was very modest.

REFERENCE:NGI (1974)

## Example 9 (1974) - Settlement of a gravity anchor in 460 meters of water

CATEGORY	MAIN OBJECTIVE	MAIN BENEFIT
Large scale test	Evaluate new anchor concept in deep water	Design verified

### BACKGROUND AND DESCRIPTION OF PROJECT

One method studied for constructing highways across deep fjords in Norway is based on floating tunnels. These structures are intended to span the fjords at relatively shallow depth and are designed to be held in place by a system of submerged cables and anchors.

In 1974 a field test was carried out to study problems associated with the construction and installation of a concrete gravity anchor in 460 m of water, and to test procedures for maintenance and replacement of anchor cables in deep water. The block was 4.5 m by 4.5 m and 2.0 m high and had a submerged weight of 130 tons. Iron ore was used as aggregate in the concrete.



Fig. 1. Anchor block on launch skid prior to deployment

### FACTORS THAT INFLUENCED THE DESIGN OF THE MONITORING PROGRAM

The bearing capacity of the soft normally consolidated sediments was a critical factor. The bearing capacity of the sediments and the predicted settlement of the anchor block were calculated on the basis of laboratory tests performed on undisturbed samples taken from the test site. This was the first time in Norway that geotechnical tests were carried out on undisturbed samples taken at such a great water depth.

The full scale test provided a unique opportunity to measure the settlement and tilt of the anchor to verify the design computations and the applicability of the laboratory test data.

### SCOPE OF INSTRUMENTATION

A biaxial inclinometer was used to measure long-term tilt as well as the attitude of the block when it first contacted the surface of the sediments. Settlement was monitored relative to a point on the bottom of the fjord approximately 5 m from the edge of the anchor using a specially designed hydraulic measuring device. It consisted of a mercury filled reference device set on the bottom of the fjord and connected via a flexible process line to a pressure transducer fixed to the anchor. A 700 m long umbilical signal cable was run to shore for taking readings.

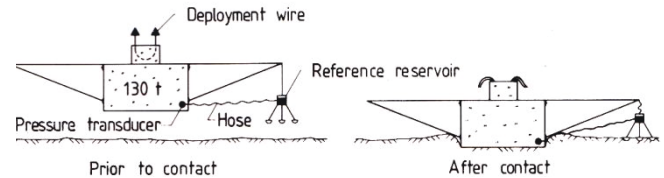
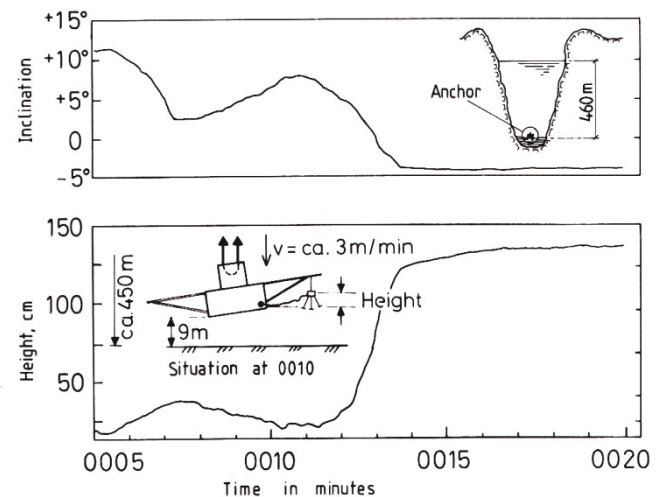
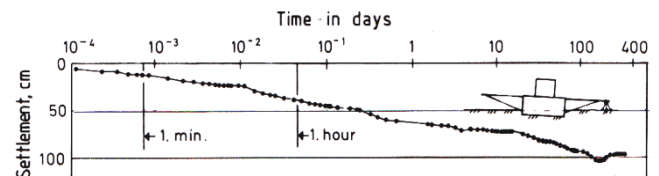

Fig. 2. Liquid level system to measure settlement



c) Fig. 3. Measurements at "touch down".

Tilt and settlement of the anchor block were monitored for one year. The time- settlement curve is shown in the figure below.



d) Measured settlement

### MOST SIGNIFICANT INFORMATION DERIVED FROM THE MONITORING PROGRAM

- Observations of inclination and settlement of the test anchor showed that an anchor could be installed satisfactorily in spite of the low factor of safety against a bearing capacity failure.
- Measured settlement agreed favorably with predictions thereby confirming both theory and the applicability of the laboratory test data.

REFERENCE: Flaate and Janbu (1975)

## Example 10 (1977) - Zoned rockfill dam with inclined core of moraine till

CATEGORY	MAIN OBJECTIVE	MAIN BENEFIT
Construction control and performance monitoring	Verify new design concept	Design verified and reduced cost

### BACKGROUND AND DESCRIPTION OF PROJECT

Monitoring programs often have more than one function. For example, for an embankment dam instrumentation systems used for construction control may be used as well for long-term performance monitoring. Likewise, a monitoring program may yield benefits other than to simply document performance. This is illustrated by the following example.

A rockfill dam, completed in 1976, had a height of 129 m, crest length of 400 m and a total volume of 4.7 million cubic meters. It had a thin core of moraine till, sand filters, fine-grained rockfill transition zones and coarse rockfill shells. The design of the core was a compromise dictated by the amount of suitable moraine at the site, the desire to have a thin core to permit rapid dissipation of excess pore pressure during construction, and the desire to reduce the chances of arching in the core.



Fig.1. Photograph of Svartevann dam

### FACTORS THAT INFLUENCED THE DESIGN OF THE MONITORING PROGRAM

At the time, this dam differed significantly in concept and size (40 percent higher) from the existing dams in Norway. It was also the first of a number of rockfill dams of comparable height that were planned for construction in the future. Thus, the dam was thoroughly instrumented not only to verify satisfactory performance but also to provide a design basis for the future dams.

Appraisal of the stability and performance of a zoned dam depends on knowledge of pore pressure build-up and dissipation, leakage, and relative movements of different materials or zones within the dam. Total stress measurements were included in order to study arching conditions and potential for hydraulic fracturing in the relatively thin core.

### SCOPE OF INSTRUMENTATION

The instrumentation program for Svartevann Dam, Figure 1, was designed to provide measurements of the following parameters: (a) displacements of the surface and within the body of the dam, (b) seepage through the core, and (c) internal stresses, i.e., pore water pressure and total earth pressure in the core and filter zone.

The instrumentation comprised 141 surface monuments, 8 settlement reference plates along the crest, 28 strain meters for measuring internal strains, 4 inclined and 4 horizontal inclinometer casings for measurement of internal displacements, and one leakage monitoring station. Altogether 30 pore pressure piezometers were installed in the dam to monitor construction pore pressures and the gradients across the core during operation of the dam. A total of 60 total stress cells were installed for monitoring soil stresses in the core and filter zones. Near the right abutment and crest where tensile stress may occur, and in the region of core-shell stress transfer these instruments were placed in rosette groups to permit determination of the principal stresses and directions.

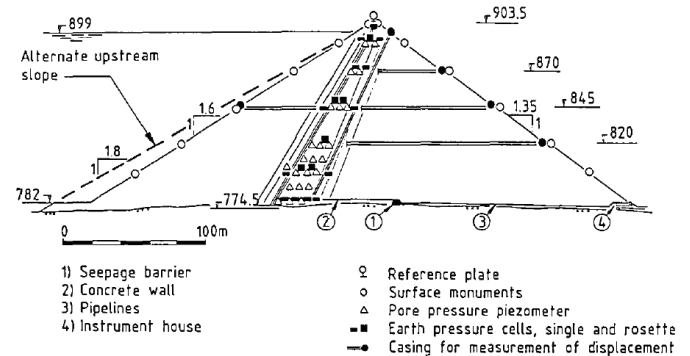

Fig. 2. Main instrumented cross section

### MOST SIGNIFICANT INFORMATION DERIVED FROM THE MONITORING PROGRAM

No unexpected results of any significance were observed during construction or operation of the reservoir although the total settlement of the dam was somewhat larger than predicted. Measured pore pressures in the core were modest and dissipated rapidly. Leakage was small.

In the stability analysis of the dam it had been recognized that if high construction pore pressures occurred and did not dissipate quickly it might have been necessary to flatten the upstream slope. Therefore, preparations were made in the base of the dam to enable a change in the upstream slope as can be seen in Figure 2. However, upon reviewing the measurements obtained during the first two construction seasons, it was concluded that this was not necessary. This decision was based on the measured pore water pressures and in-situ measurements of the shear strength of the rockfill determined from plate loading tests. The consequence of this decision was a reduction in construction time and a significant savings in the cost of the dam.

REFERENCE: (DiBiagio et al. (1982).

## Example 11 (1980) - Monitoring contact pressure at rock/ice interface beneath a glacier

CATEGORY	MAIN OBJECTIVE	MAIN BENEFIT
Basic Research	Monitor sub glacial ice pressure and velocity of ice flow	Improved knowledge

### BACKGROUND AND DESCRIPTION OF PROJECT

One of the most difficult tasks in glaciology is to make in situ measurements at the ice/bedrock interface beneath a glacier. Very little information can be acquired about subglacial processes using boreholes drilled from the surface. A unique opportunity to access the ice-rock interface under a glacier arose during construction of a hydropower station in south-west Norway. Part of the water used for power generation is melt water from the Bondhusbreen glacier which is collected via a system of tunnels and vertical shafts through the rock under the glacier. The ice is 160 m thick at the intake shafts.

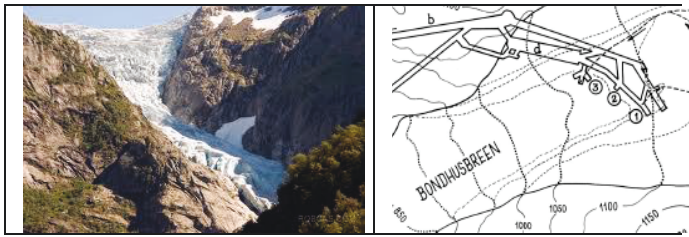

Figure 1. Bondhusbreen and tunnel system under the glacier

The glaciology department at the University of Oslo took advantage of the situation and initiated a research program at Bondhusbreen to observe and monitor subglacial processes such as erosion, sediment transport, ice pressure, hydrology and rock deformation. In order to make observations and install instruments, ice tunnels and cavities were formed starting at one of the vertical shafts (intake 3) by melting the ice over the bedrock using a system of hot water sprinklers.

### PRESSURE AND STRAIN MEASUREMENTS IN BEDROCK

In 1980 ten vibrating-wire pressure transducer were installed to measure contact pressure at the ice/bedrock interface.

- 3 were mounted on an asymmetrical steel and concrete obstruction (to simulate a *rouche moutonné*), 1 m long, 40 cm wide and 50 cm high shaped as shown in Figure 2
- 5 were mounted on a symmetrical domed-shaped obstruction, 1 m in diameter and 15 cm high
- 2 were installed flush with the bedrock surface.

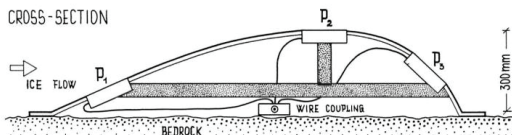

Fig. 2. Cross section through the roche moutonnée

Strain in the Precambrian bedrock was measured at two points using vibrating-wire strain gauges, with a gauge length of 20 cm. These were installed in small niches cut in the bedrock. Sliding velocity of the ice and temperature were also measured. NGI supplied and installed the pressure sensors, strain gauges and data acquisition system.

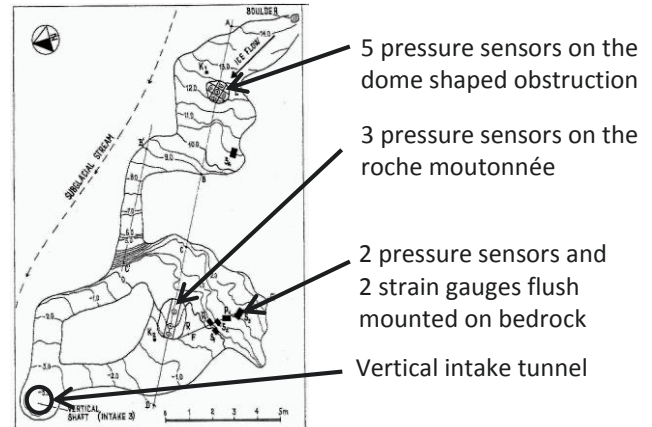

Figure 3. Outline of tunnels and cavities melted out in the ice

### SAMPLE OF TYPICAL MEASUREMENTS

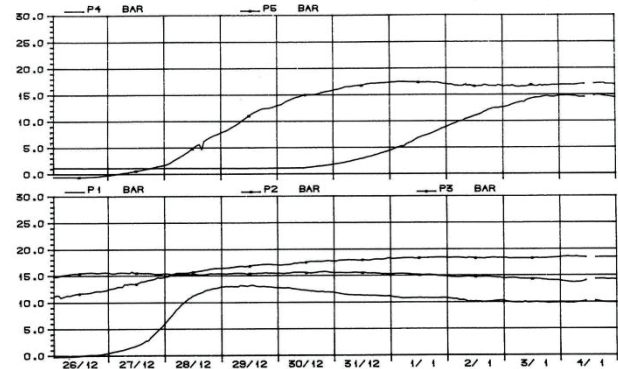

Figure 4. Ice pressures measured as the ice flow filled the cavity and came in contact with the 5 pressure sensors on the dome-shaped obstruction.

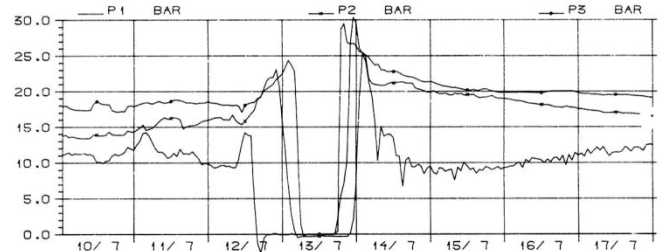

Fig.4. Recorded ice pressure showing a drop in pressure as a cavity formed over the roche moutonnée and pressure build up again when the ice returned.

The deformation of the bedrock was elastic, The maximum measured strain was 150 microstrain. The average sliding velocity of ice flow was 33 mm/day during the test period.

REFERENCE: Hagen et al. (1983)

## Example 12 (1981) - Long term behaviour of an offshore gravity base structure

CATEGORY	MAIN OBJECTIVE	MAIN BENEFIT
Structural monitoring	Monitor installation and operation of offshore structure	Design verified

### BACKGROUND AND DESCRIPTION OF PROJECT

Performance measurements provide information that the design engineer needs to carry out a design verification study. Observed discrepancies between field predictions and actual performance design provide a basis for changing assumptions to obtain better designs in the future.

Gravity base structures used for offshore oil drilling and production platforms are built in protected waters near shore, and then towed to the offshore location and set on the sea floor in the course of a few days. To illustrate the immense size of these structures, Mobil's Statfjord B platform, Fig. 5.1, which was installed in 149 m of water in 1981 has a base area of 18,000 sq. m and a net weight of 800,000 tons.

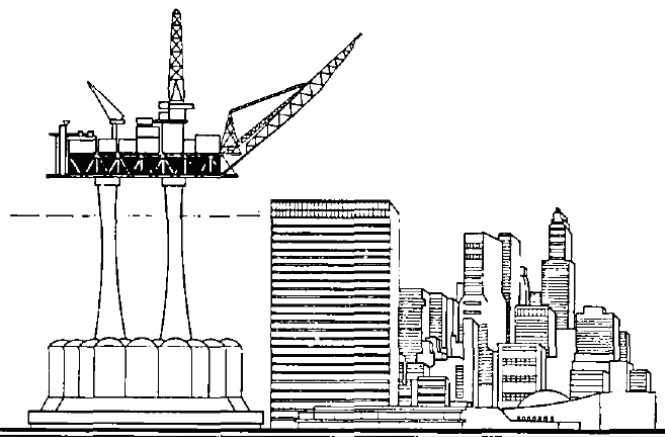

Fig. 1. Statfjord B gravity base structure compared to United Nations building and Manhattan skyline.

### FACTORS THAT INFLUENCED THE DESIGN OF THE MONITORING PROGRAM

The introduction of the gravity base concept for fixed offshore drilling and production platforms in the early 1970's brought with it a multitude of novel design problems. There was little precedence to base the design of these new structures on. Under these circumstances, field performance data from the first structures was vitally needed to confirm satisfactory performance and to check the validity of the assumptions used in the designs.

For these structures emphasis was placed on monitoring behaviour during storm periods and to detection of changes in the response of the structure and foundation caused by repeated cyclic loading.

### SCOPE OF INSTRUMENTATION

As an example, the measurements included in the long-term performance monitoring program for the Statfjord B structure are listed in Table 1.

Table 1. Instruments for long-term performance monitoring

Wind speed and direction	Tidal variations
Inclination and settlement	Strain in concrete, top/bottom of tower
Water pressure under base	Strain in concrete braces at mudline
Pore water pressure	Dynamic motion of deck and base

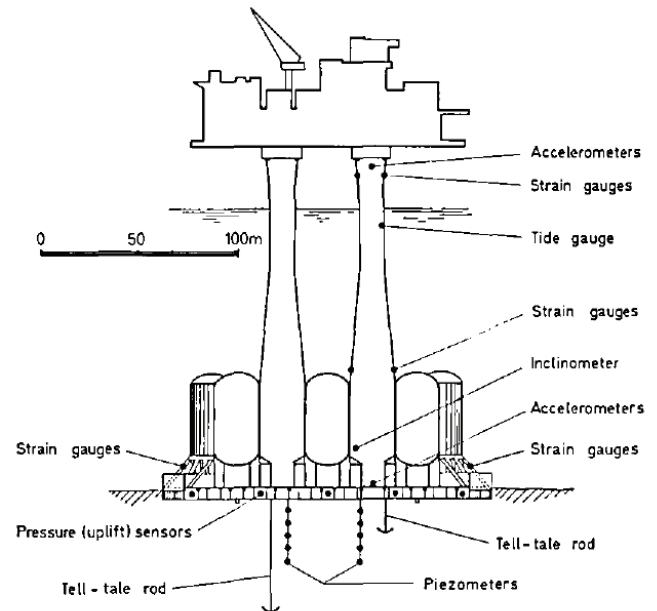

Fig. 2. Instrumentation for monitoring the long-term performance of Statfjord B.

### MOST SIGNIFICANT INFORMATION DERIVED FROM THE MONITORING PROGRAM

- Measurements have enabled safe and optimum installation of structures.
- Measurements have verified design procedures for prediction of penetration forces, contact pressures, settlement, build-up and dissipation of excess pore pressures during and after storm periods.
- Analysis of dynamic motion data has confirmed that actual behaviour of the structure and foundation is in general agreement with predictions made using current design methods.

The introduction of the gravity base platform concept in the early 1970's brought with it a multitude of novel design problems. Now, however, many of the original uncertainties are no longer points of concern. Much of this evolution can be credited to the extensive monitoring programs that have been carried out on these structures.

REFERENCE: DiBiagio and Høeg (1983)

## Example 13 (1982) - Measurement of dynamic avalanche parameters

CATEGORY	MAIN OBJECTIVE	MAIN BENEFIT
Research	Measurement of impact pressures and velocities of avalanches	Improved understanding

### BACKGROUND AND DESCRIPTION OF PROJECT

Snow avalanches are one of the most frequent and deadliest natural hazards in Norway. In 1972 the government commissioned NGI to establish a research center for studying avalanches and all aspects of avalanche mitigation. A center was established at Ryggfonn in Western Norway at a site where avalanches occur frequently enabling researchers to closely examine and study avalanches in full scale. Explosives can also be used to release the avalanches more reliably and at the exact desired time. The research at Ryggfonn focuses on the dynamics of natural avalanches, the effectiveness of mitigation measures and measurement of forces on various types of structures erected in the avalanche path.

Measurements of full-scale avalanches are challenging due to the harsh condition within an avalanche. However, they are indispensable to gain in-depth understanding of the flow behavior of avalanches and to crosscheck the scaling used in small-scale experiments. Full scale measurements also form the basis for developing and calibrating numerical models.

**INSTRUMENTATION OF THE AVALANCHE TEST SITE** Since 1972 a variety of instruments have been installed at the avalanche test site, Figure 1. At present, the instrumentation consists of:

- Load plates and piezo-electrical load cells at 5 locations;
- Pulsed Doppler radar;
- LED velocity sensors at 2 locations;
- An array of geophones;
- A field hut for automatic data acquisition



Fig. 2. Avalanche on 2000-02-07 at Ryggfonn test site



Fig. 3. Test structure with 3 load plates to measure impact forces during an avalanche (1982)

### SAMPLE OF TYPICAL MEASUREMENTS

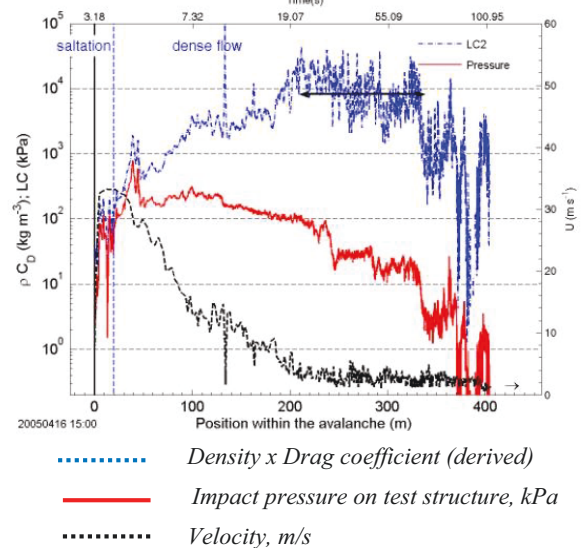

Fig. 4. Measurements on test structure during an avalanche  
Maximum observed velocities have been measured up to 60 m/s for dry-mixed avalanches. Impact pressures reached more than 600 kPa during wet snow avalanches.

REFERENCE Gauer, P. et al (2007)

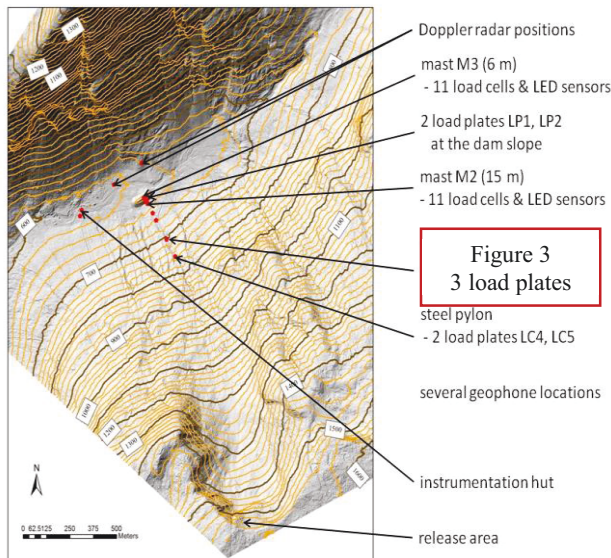

Fig. 1. Overview of the Ryggfonn test site and instrumentation

## Example 14 (1985) - Large scale offshore soil penetration test in 220 meters of water

CATEGORY	MAIN OBJECTIVE	MAIN BENEFIT
Full scale test	Compare predictions to actual performance	Design verified

### BACKGROUND AND DESCRIPTION OF PROJECT

A gigantic soil penetration test was carried out in the North Sea in 1985 to determine the penetration resistance of the concrete skirts for a proposed gravity structure. In more than 200 m of water a concrete test panel, 2.4 m wide, 0.4 m thick and 23 m high was successfully penetrated 22 m into the seabed twice to provide important design information for Statoil's Gullfaks C platform, Figure 1. The Gullfaks C which was installed in 1989 has 1400 running meters of concrete skirts of the same thickness and height as the test panel. The test structure was made up of two steel cylinders, 6.5 m in diameter, linked with the heavily instrumented test panel, Fig. 2. The 360 ton test structure was penetrated into the seabed by the combined action of its own dead weight and suction applied inside the cylinders.



Fig. 1. Lower end of test structure. Instruments for measuring soil friction, pore water pressure and earth pressure on the concrete panel can be seen.

### FACTORS THAT INFLUENCED MONITORING DESIGN

To fully understand the penetration resistance of the test panel it was necessary to be able to differentiate between point resistance and wall friction. Thus, these measurements were included in the monitoring program together with related measurements of total earth pressure and pore water pressure on the concrete test panel. In addition a number of other types of instruments were required for operational reasons.

### SCOPE OF INSTRUMENTATION

The 13 types of instruments or measurement systems that were installed on the test structure are summarized in Table 1. There were 70 measuring points.

Table 1. List of instruments in the monitoring program

- |                                   |                           |
|-----------------------------------|---------------------------|
| • Load cells on tip of panel      | • Draught and inclination |
| • Soil friction on side of panel  | • Echo sounders           |
| • Total earth pressure            | • Bottom clearance        |
| • Pore water pressure             | • Ballast water flow      |
| • Strain in concrete panel        | • Cone penetrometers      |
| • Water pressure inside cylinders | • Shallow gas detector    |

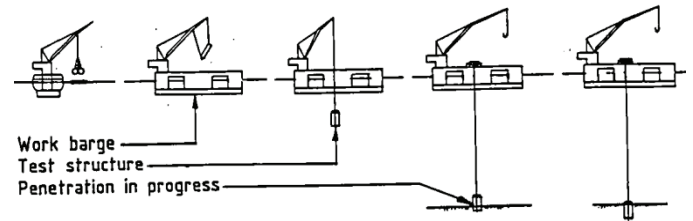

Fig.2. Marine operations in the offshore penetration test

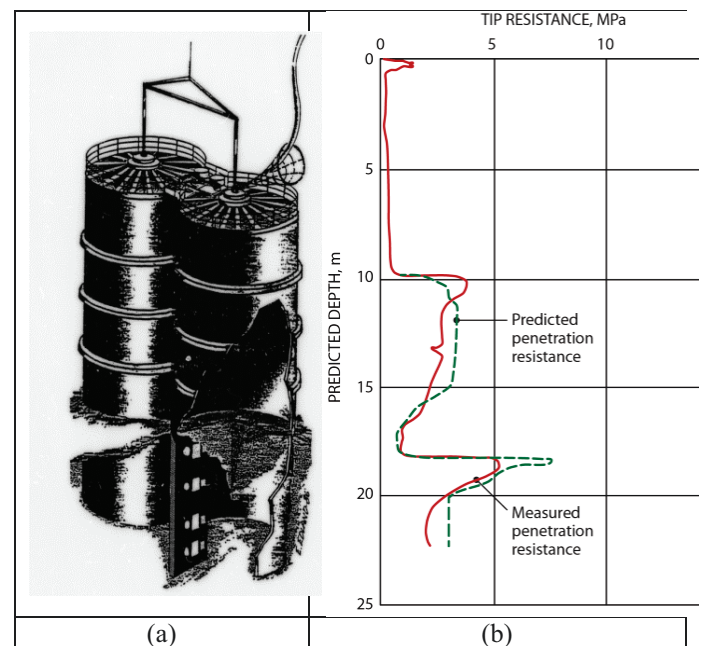

Fig.2(a). Sketch showing the structure penetrating the sea bed.

Fig 2(b). Measured and predicted tip resistance of test panel

### MOST SIGNIFICANT INFORMATION DERIVED FROM THE MONITORING PROGRAM

- The penetration resistance of the panel tip in dense sand was much lower than predicted on the basis of cone penetration tests.
- Wall friction in the sand was influenced significantly by the water pressure within the 2 steel cylinders.
- Penetration rate had little effect on the tip penetration resistance.
- The level of confidence in the proposed design parameters for the Gullfaks C structure and ability to correctly predict soil response were significantly enhanced by the field tests.

REFERENCE Tjelta, Guttormsen and Hermstad (1986)

## Example 15 (1987) - Rockfill dam with central core of asphaltic concrete

CATEGORY	MAIN OBJECTIVE	MAIN BENEFIT
Construction control	Verify new design concept	Design verified

### BACKGROUND AND DESCRIPTION OF PROJECT

This example deals with Storvatn Dam, Figure 1, a Norwegian rockfill dam that has an inclined core of asphaltic concrete. Construction of the dam was completed in 1987. It has a maximum height of 90 m, a crest length of 1,475 m, and a total volume of about 10 million cu m. Most rockfill dams in Norway have moraine cores; however, an asphaltic concrete core was chosen at this site because it was the best alternative. The primary objective of the instrumentation program was to determine the deformations of the dam.



Fig.1. Storvatn dam

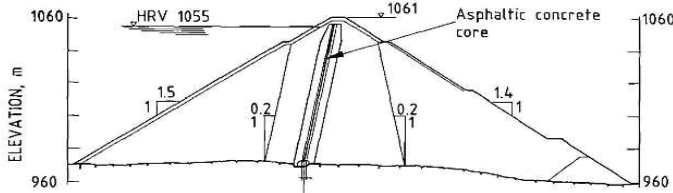

Fig.2 Cross section Storvatn dam

### FACTORS THAT INFLUENCED THE DESIGN OF THE MONITORING PROGRAM

Dense asphaltic concrete is virtually watertight; thus, only a thin membrane is required to prevent leakage. Usually the width is set at about 0.8 percent of the water head, with a minimum thickness of 40 to 50 cm. In the case of Storvatn Dam the 90 m high membrane varies in thickness from 80 cm at the bottom to 50 cm at the top. Since it is so narrow, the asphaltic concrete barrier constitutes merely a thin membrane which will follow the displacements of the adjacent fill material. Therefore, the deformations of the asphaltic concrete must be compatible with the movements of the surrounding fill without undergoing any fissuring or crack that could cause leakage.

### SCOPE OF INSTRUMENTATION

The main objective of the instrumentation program was to determine the strains that occur in the dam, primarily in the asphaltic concrete core and in the adjacent supporting material. In particular it was desirable to find out if there is any tendency for the width of the core to expand or contract, or to "hang up" on the supporting material as a result of differences in compressibility of the core and surrounding material.

The instrumentation program for Storvatn Dam included 3 instrumented cross sections comprising in all: 3 weir stations; 284 survey monuments; 12 inclined, vertical or horizontal inclinometer casings; 28 extensometers for strain measurements in the asphaltic concrete; 10 extensometers for detecting relative movements between the core and adjacent transition zone; 10 special devices for detecting shear deformations in the transition zone; and 10 pressure cells for measurement of stresses in the rockfill. Special instruments for monitoring strain in the core and shear deformations in the adjacent filter zone are shown in Figure 3.

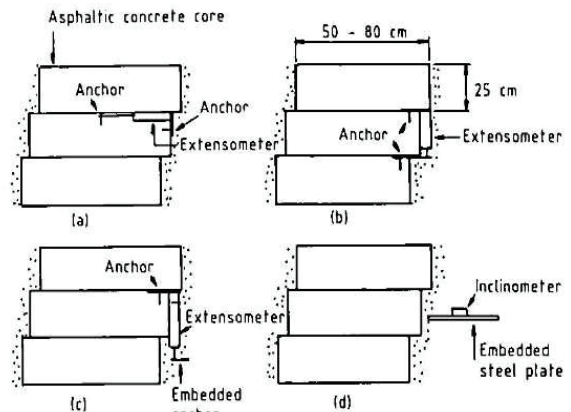

Fig.3. Special instruments to monitor behavior of core:

- (a) Horizontal strain in the core
- (b) Vertical strain in the core
- (c) Relative displacement at core/filter interface
- (d) Embedded plate to detect shear strains in filter

Elev. m	Horizontal deformation			Vertical deformation		
	Value mm	Ave. mm	Strain %	Value mm	Ave. mm	Strain %
1046	+0.8 +0.7	+0.75	+0.25	-0.6 -1.2	-0.90	-0.45
1016	+0.2 -0.3	-0.50	-0.14	-0.7 -1.0	-0.85	-0.43
986	-1.4 -2.2	-1.8	-0.45	-0.5 -0.6	-0.55	-0.27

Fig. 3. Measured strain in core at end of construction

Note: Negative values denote compression

### MOST SIGNIFICANT INFORMATION OBTAINED

The benefit of this monitoring program lies in the documented deformations of this type of new dam during construction and operation. The data have been used to calibrate the analytical models used in the design of the dam. This information is naturally extremely valuable to the designer of subsequent dams with asphaltic concrete cores.

REFERENCE: Høeg, K (1993)

## Example 16 (1989) - Model test of a suction anchor

CATEGORY	MAIN OBJECTIVE	MAIN BENEFIT
Large scale test	Determine pull-out capacity of suction anchors	Design verified

### BACKGROUND AND DESCRIPTION OF PROJECT

The *Snorre A* platform in the North Sea is a so-called tension-leg platform (TLP), i.e., it is a floating structure held in place by vertical steel tethers connected to suction anchors at the seabed. The water depth at the site is 310 m. Suction anchors have significant economical advantages compared to anchor piles. When the structure was being designed there was little practical and theoretical experience with suction anchors. Therefore, a series of field model tests were performed in 1993 by NGI to check the validity of foundation procedures developed for designing these anchors.

### FACTORS THAT INFLUENCED THE DESIGN OF THE MONITORING PROGRAM

In storm periods, the platform will drift off, changing the tether angle to perhaps as much as 10°. This will increase the vertical force in the tether and subject the suction anchor to a horizontal force and an overturning moment. At the same time, the anchor will be subjected to cyclic forces due to wave loading. The field model test was designed to simulate these loading conditions. Therefore, the test program consisted of one static test and three cyclic tests with the loads inclined at an initial angle of 10° relative to vertical.

The model, Figure 1, consisted of four circular steel cylinders 36-inches (914 mm) in diameter welded together. The skirts were 900 mm long and 22.5 mm thick

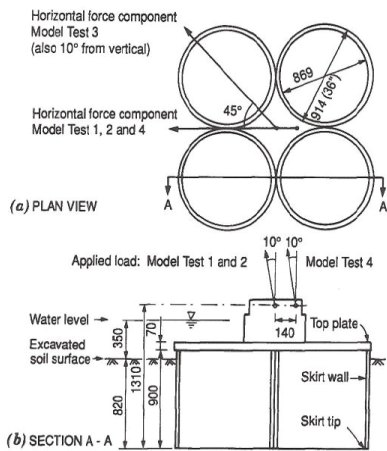

Fig. 1. Details of model, dimensions in mm)

### SCOPE OF INSTRUMENTATION

The following instrumentation was used in the model tests: vertical load (1 transducer), inclined load (1 transducer), displacements of the model [6 linear variable differential transducers (LDVTs)], inclination (2 transducers at 90°), cell pressure in the tops of skirt compartments (4 transducers), earth pressure at skirt tip (2 transducers), pore pressure

at skirt tip (8 transducers), pore pressure in clay below and beside the model (4 transducers), and 1 barometric pressure gauge.



Fig. 2. Photograph of model after a cyclic test

### SAMPLE OF TEST RESULTS

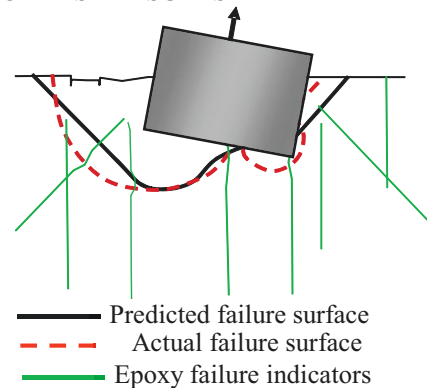

Fig. 3. Failure surface after static load test.

One unique feature of the test was that NGI's predictions were submitted to the client in a sealed envelope before the field tests began. The predicted static and cyclic failure loads are summarized and compared in Table 2.

Table 1. Predicted and measured Pull-out capacity

Test	Type of test	Failure load (kN)		
		Predicted	Measured	Ratio
1	Static	138	137,7	1,00
2	Cyclic	118	112,9	1,05
3	Cyclic	105	99,5	1,06
4	Cyclic	92	90,5	1,01

### MOST SIGNIFICANT INFORMATION DERIVED

The tests showed that the calculation procedures previously developed for foundation of offshore gravity base platforms were also well suited for design of suction anchors.

REFERENCE: Andersen et al. (1993)

## Example 17 (1995) - Monitoring stresses in North Sea pipelines

CATEGORY	MAIN OBJECTIVE	MAIN BENEFIT
Structural monitoring	Document stresses in pipelines	Design verified

### BACKGROUND AND DESCRIPTION OF PROJECT

The landfall for the two 620 km long, Europipe 1 and Europipe 2 gas pipelines from the oil fields in the North Sea crosses shallow coastal wetlands on the German coast in the Wadden Sea National Park of Lower Saxony. To avoid disturbing these unique wetlands of extreme environmental importance and sensitivity, it was decided that the pipelines would pass under the protected areas in a 2.5 km long tunnel with a diameter of 3.5 m. The tunnel was constructed by the telescope pipe jacking method.

The connection between the pipelines and the Landfall tunnel is made at an offshore Tie-in Chamber, a cylindrical concrete structure 14 m in diameter supported on driven piles. Figures 1 and 2.



Fig. 1. Tie-in Chamber during construction

### Biaxial inclinometers

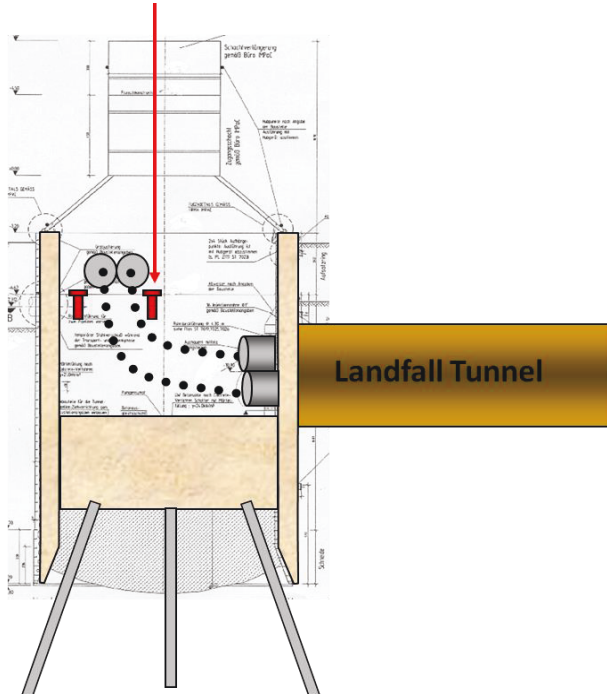

Fig. 2. Section through the Tie-in Chamber

### FACTORS THAT INFLUENCED THE DESIGN OF THE MONITORING PROGRAM

The design pressure for the two gas pipelines is 156 Barg. They enter one side of the Tie-in Chamber where the connection is made to the two pipes in the Landfall tunnel. As shown in Figure 3, the pipelines change direction in the Tie-in Chamber. This change in direction creates a maximum force of the order of 25000 MN on the Tie-in Chamber and induces large stresses in the pipelines.

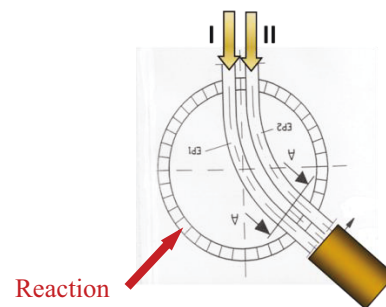

Fig. 3. Cross section

### SCOPE OF INSTRUMENTATION

Both pipelines were instrumented with strain gauges to monitor the stresses as illustrated in Figure 4. Biaxial inclinometers were used to measure tilt of the Tie-in Chamber.

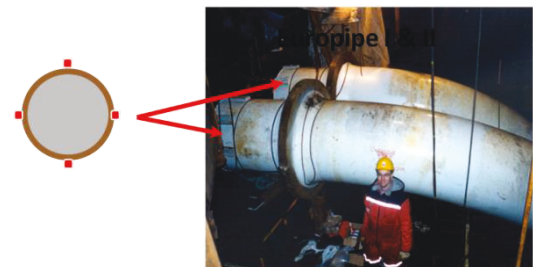

Fig. 4. Location of strain gauges

### SAMPLE OF STRAIN MEASUREMENTS IN EUROPIPE 1

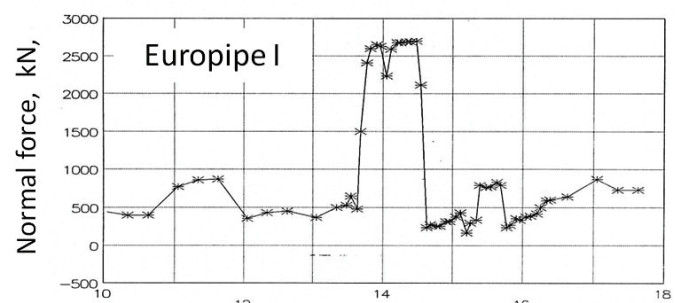

Fig. 5. Pressure test of Europipe 1

## Example 18 (2001) – Ormen Lange Piezometers

CATEGORY	MAIN OBJECTIVE	MAIN BENEFIT
Seabed Instrumentation	Determine in situ pore pressures in target soil layers	Design assumptions verified

### BACKGROUND AND DESCRIPTION OF PROJECT

During the early stages of the Ormen Lange slope stability evaluations it became apparent that the potential for excess pore pressure in critical soil formations was key in explaining the failure of the relatively flat submarine slopes of the original topography. Measurements of pore pressures were necessary to confirm this finding. However, piezometers for autonomous monitoring at an undeveloped offshore field did not exist. The purpose of this project was to develop and install piezometers for long-term pore pressure monitoring

### FACTORS THAT INFLUENCED THE DESIGN OF THE MONITORING PROGRAM

The Ormen Lange field was located some 200 km from the coast, at a location with no existing infrastructure and water depths ranging from 270 to 1300m. Due to the remote location, all equipment had to be fully autonomous (power and data storage), and capable of interaction with remotely operated vehicles (ROV) for data recovery and service. Further, the location is a popular fishing area, requiring all equipment to meet requirements for trawling protection. Installation depths were up to 200m below seabed, with installation via standard geotechnical drill string (5" ID). The developed solution is an ROV friendly seabed station carrying electronics and power, connected to a hydraulic piezometer string installed in a geotechnical borehole.



Fig. 1. ROV trial to verify operation and access

### SCOPE OF INSTRUMENTATION

Four piezometer installations were required in the main development field and back wall of the Storegga slide escarpment. In addition, lance-type piezometers were installed on the North Flank. The installations operated for several years until it was decided to decommission them.

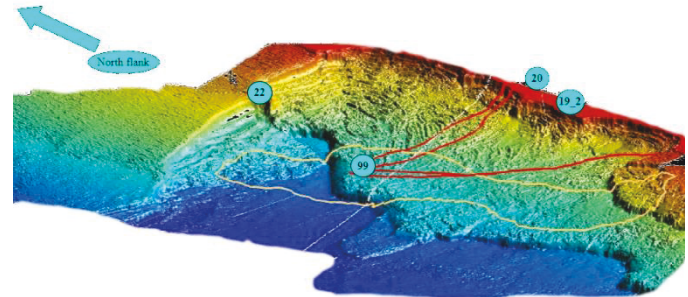

Fig. 2. Installation locations 19\_2, 20, 22, 99 and North Flank

### MOST SIGNIFICANT INFORMATION DERIVED

The piezometers provided the data necessary to verify design assumptions and confirm the slope stability assessment. The stability assessment was itself a critical factor in the decision to develop the Ormen Lange field. Further, the implementation of the piezometers as an autonomous subsea installation has led to a series of refinements and improvements in subsea piezometer technology. Finally the comparison of the results from the long-term piezometer monitoring to dissipation tests performed using a piezoprobe showed that dissipation testing in hard, overconsolidated marine clay under offshore drilling conditions is not appropriate or reliable.

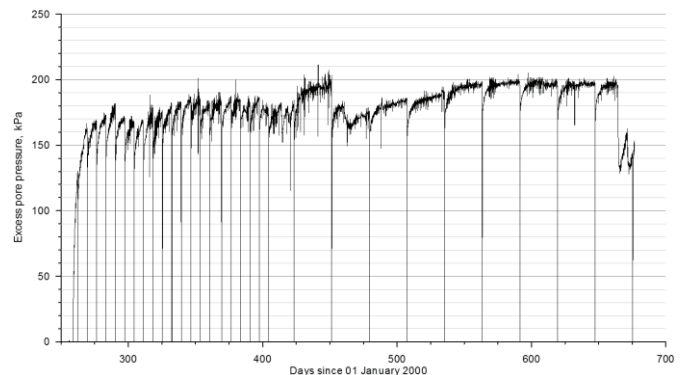

Fig. 3. Excess pore pressure at installation 19\_2. The regular pressure drops are zero checks of the pressure sensors.

REFERENCES: Strout & Tjelta (2005); Tjelta, T.I. et al (2002).

## Example 19 (2003) – An early warning system (EWS) for detecting rock falls

CATEGORY	MAIN OBJECTIVE	MAIN BENEFIT
Full scale field test	Develop a microseismic early warning system	Five year performance data obtained

### BACKGROUND AND DESCRIPTION OF PROJECT

The topography of Norway consists of 75% exposed rock, primarily in the form of steep slopes or rugged mountains that are subjected to varying amounts of precipitation as well as extreme seasonal cycles of freezing and thawing. Consequently, one of the principal geohazards is the potential for rock falls or rock and ice slides. Considerable effort is being put into developing suitable warning systems to protect life and property. An example is the microseismic early warning system (EWS) installed by NGI to monitor a long section of railway line that is vulnerable to ice and rock falls.

### FACTORS THAT INFLUENCED THE DESIGN OF THE MONITORING PROGRAM

A 500m long section of railway line in northern Norway is exposed to frequent ice and rock falls. This section was chosen in 2003 to be a pilot site for the developing and testing a warning system in cooperation with Jernbaneverket. A microseismic system using subterranean geophones was chosen, with a line of geophones placed along the uphill side of the track. The geophones are vertically cast in concrete to attain good coupling to the surrounding track substrate. The warning system was in operation until 2010.

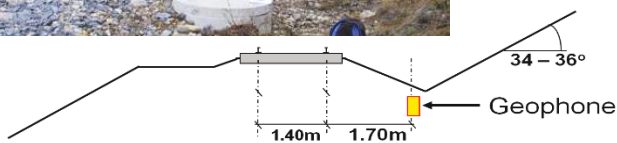

Fig. 1. View of site and Cross section of instrumented side

### SCOPE OF INSTRUMENTATION

The main components of the acquisition system are the geophone array, a seismic data logger and an industrial PC. The geophone array is a custom-built cable with 24 geophones. The PC controls the logger and analyses incoming data sets. A wireless router allows communication and automatic SMS based warning to users.

The system has been designed to distinguish between passing trains, maintenance vehicles, low energy rock falls, electrical noise, and ice and rock falls of different categories.

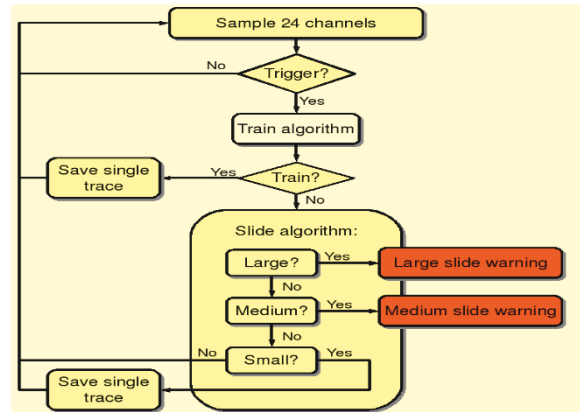

Fig. 2. Block diagram of the EWS processing and alarm generation system

For the first three years after installation (2004-2007), the system was used as a monitoring system only, and all events were recorded and used primarily to evaluate the performance of the system. During 2005, a test of controlled rock falls was made to gain more rock fall events. This data was used to optimise the parameters of the three slide algorithms used to evaluate whether a warning situation exists or not.

### TYPICAL EVENT REGISTRATION

In a warning system such as this, there are many different events that can trigger the system. Two examples are shown below.

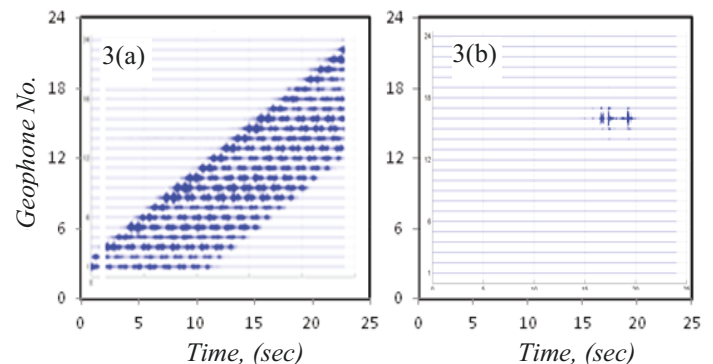

Fig. 3(a): Typical signals from a passing train. The slope of the curve indicates a velocity of 65 km/hour

Fig. 3(b): Signals generated by a 1200 Kg rock fall that blocked the rail line on 11 June 2005

REFERENCE: Cleave, Myrvoll and N alsund (2009)

## Example 20 (2007) - Observational method applied to a large tailings dam

CATEGORY	MAIN OBJECTIVE	MAIN BENEFIT
Construction control	Input for the Observational Method	Design modified on basis of measurements

### BACKGROUND AND DESCRIPTION OF PROJECT

This case history deals with the Zelazny Most tailings dam in south-west Poland, Figure 1. The ring-shaped dam has a perimeter of 15 km, area of 20 km<sup>2</sup>, and is one of the largest tailings dams in the world. Approximately 80,000 tons of waste are transported hydraulically to the dam every day. Deposition of tailings started in 1975. The current height of the dam is between 22 to 60 m above the original ground surface.



Fig. 1. Aerial view of the Zelazny Most tailings dam

The elevation of the dam is raised by the upstream method of construction as illustrated in Figure 2.

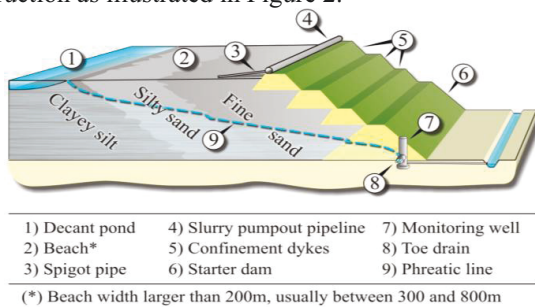

Fig. 2. Cross section of part of the dam

### SCOPE OF INSTRUMENTATION

The monitoring program includes measurements of:

- Mining-induced seismicity: 2 seismographs and 10 biaxial accelerometers.
- Pore water pressure and elevation of the phreatic line: 1800 open standpipe piezometers and 300 vibrating-wire piezometers in boreholes. The latter were installed by the fully grouted method (Mikkelsen and Green 2003).
- Surface displacements: 350 benchmarks for geodetic and GPS measurements plus an automatic Total Station with 23 target mirrors.
- Measurements of subsurface displacements of the dam and foundation: ~50 inclinometer installations.

### PERFORMANCE OF THE DAM

Since the tailings dam is built by the upstream construction method, Figure 2, the main concern initially was instability due to potential flow liquefaction of the tailings. Therefore, the first inclinometer installations installed through the dam into the foundation were fairly

shallow. However, after a few years of operating the dam, geodetic data and inclinometer measurements showed some sections of the dam were moving more or less as semi-rigid bodies, and deeper inclinometers were installed in 2003.

Subsequent measurements have disclosed zones of concentrated deep displacements far below the dam as can be seen in Figure 3. The Pliocene clay has been pre-sheared during two periods of glaciations, and the friction angle is probably reduced down close to its residual value. Figure 3, for example shows the measured horizontal displacements at the North dam between 2011 and 2012. The dam and subsoil above elevation 80 m are sliding along a shear plane in the Pliocene clay at about elevation 80 m. This is at a depth 35 m under the original ground surface. There is also a zone of concentrated shear at about elevation 70 m.

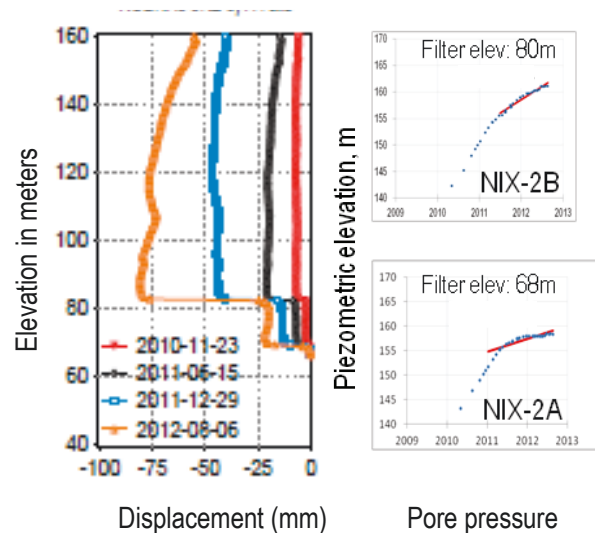

Figure 3. Measured horizontal displacements and pore pressure in the shear zones at the North dam

### MOST SIGNIFICANT INFORMATION DERIVED

The design and operation of the Zelazny Most tailings dam is an excellent example of the use of the *Observational method* in geotechnical engineering. Measurements have resulted in design changes and remedial measures such as:

- moving the dam crest upstream to flatten the average downstream slope;
- constructing stabilizing berms at the dam toe; and
- installing relief wells in the foundation to reduce pore water pressures.

REFERENCE: Jamiolkowski, M. et al. (2010)

## Example 21 (2008) - Crack detection in a steel girder bridge

CATEGORY	MAIN OBJECTIVE	MAIN BENEFIT
Structural monitoring	Get input for an Early Warning System	Remedial action can be taken

### BACKGROUND AND DESCRIPTION OF PROJECT

The bridge is a 70 year old 950 m long steel girder bridge, in Gothenburg Sweden. It consists of a concrete deck slab resting on nine continuous steel girders supported by more than 50 steel columns. It is the main communication line across the Göta river.



Fig.1. View of part of the bridge

The time in service for the bridge is approaching its design life of 80 years. A routine inspection in 1999 disclosed large cracks in the flanges of steel girders above the support columns. These were considered to be due to a combination of fatigue after many years of service and the low quality steel used in the bridge when it was constructed in 1936 to 1939.



Fig 2. Crack in the top flange of a girder

The cracks were repaired. The bridge will be replaced but not before 2020. Therefore, the Traffic Authority evaluated various technologies for integrity monitoring of the existing bridge in order to detect any unexpected structural behavior. The final choice was an early warning system based on optical fiber sensing technology.

### DESCRIPTION OF THE EARLY WARNING SYSTEM

#### Monitoring technology

- The EWS utilizes a distributed optical fiber sensing technology based on the Brillouin scattering effect.
- The sensing fibers monitor 5 of the most heavily loaded girders over the entire length of the bridge.
- In addition a distributed temperature sensing fiber is installed for temperature compensation.

#### Primary monitoring and analysis functions

- Detection and localization of new cracks in the girders
  - Monitor strains at all measurement points every 2 hours
  - Detect unusual short-term and long-term strain changes
- Warnings are issued to the bridge authority for planned emergency response.

The distributed strain sensing element consists of a polyimide coated glass fiber integrated within a strip of glass fiber reinforced thermoplastic composite tape. These are bonded to the steel girders using appropriate adhesive and covered with aluminum tape for physical and chemical protection. The optical fiber needed for temperature measurements was simply clamped to the structure.

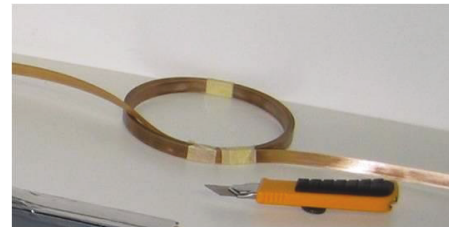

Fig.3. Coil of the optical fiber sensing tape

The measurements are performed with a distance sampling interval of 0.1 m along the 5 instrumented girders making the total number of monitoring points more than 50000 for strain and another 50000 for temperature. In case of crack detection, detection of unusual strain variations with time, detection of strain above preset threshold levels or detection of system malfunctions, warning messages are sent to responsible entities in the form of e-mail and SMS for further study or emergency and preventative actions.

Site acceptance tests were carried out to verify satisfactory function of the fiber optic monitoring system in accordance with specifications. These tests were completed in autumn 2008. The system will be kept in operation until a new bridge is completed, sometime after 2020.

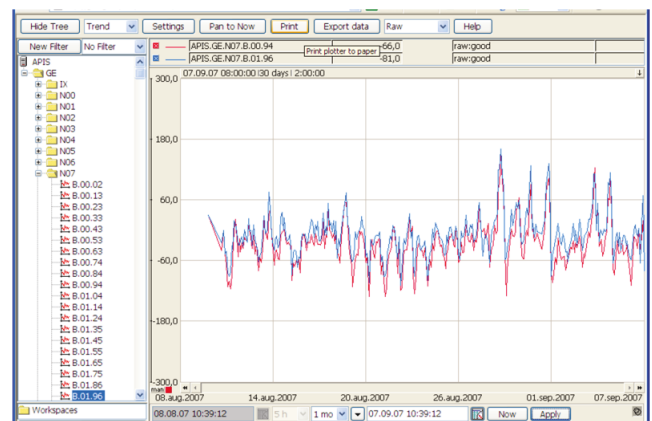

Fig. 4. Thirty day record of strain for 2 points 10 cm apart.

REFERENCE: Myroll et al. (2009)

## Example 22 (2008) - Model tests of a torpedo drop anchor in deep water

CATEGORY	MAIN OBJECTIVE	MAIN BENEFIT
Large scale test	Determine penetration depth of anchor	Design assumptions verified

### BACKGROUND AND DESCRIPTION OF PROJECT

Fixed platforms are used extensively for development of offshore oil fields. Common examples are gravity base structures and steel jackets with piled foundations. However, their use is limited by the water depth. The Troll C concrete gravity base structure in the North Sea, which was installed in 330 m of water, is the largest fixed platform to date. In deeper waters floating structures are required and these must be held in place with mooring lines connected to subsea anchors.

Various forms of anchors have been used, for example suction anchors, driven piles and drag embedded anchors. Another form of anchor is the drop anchor, often referred to as a *torpedo anchor*. During installation it is suspended from a wire and released some distance above the seabed. When released, it falls freely and penetrates into the soil due to its velocity and weight. Figure 1 shows a typical torpedo anchor. These anchors may typically have a dry weight of 50 - 100 tons and height of 10 - 15 meters.

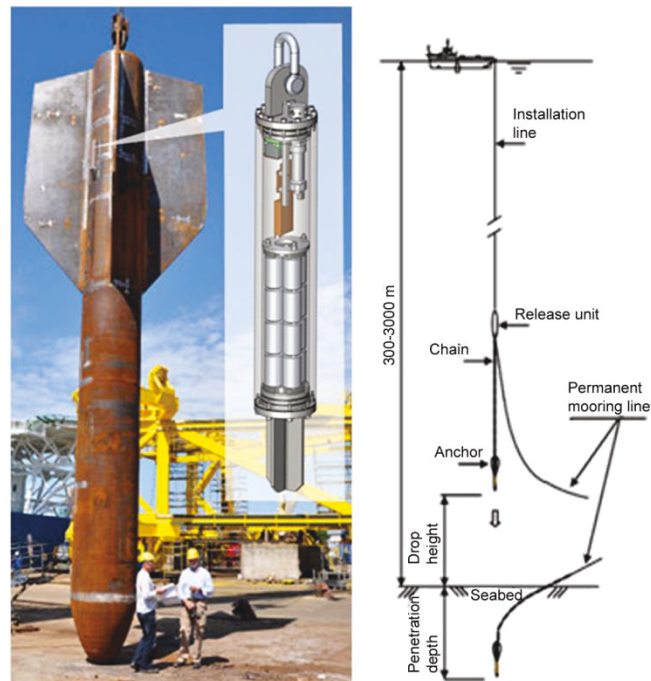

Fig. 1. Instrument module attached to a typical full size drop anchor installed at the Gjøa field in the North Sea (Ref. Statoil and Deep Sea Anchor A/S)

In 2008 a Norwegian R&D program was initiated by Statoil to test the torpedo anchor concept developed by Deep Sea Anchor AS. Two 1/3 scale test anchors were used. They were first tested in a Norwegian fjord and afterwards at the Troll field in the North Sea at a water depth of 330 m.

### FACTORS THAT INFLUENCED THE DESIGN OF THE MONITORING PROGRAM

Key parameters for evaluating the performance of the drop anchor were considered to be:

- Stability, velocity and motion of the anchor during free-fall and penetration into the soil
- Optimal free-fall distance and velocity of the anchor when it reached the sea bed
- Depth of penetration
- Pore pressure dissipation after penetration

### SCOPE OF INSTRUMENTATION

A recoverable instrumentation module (Figure 1) is attached to the anchor. The module contained a depth sensor, a biaxial inclinometer, a triaxial linear accelerometer, two pore pressure sensors and a data logger. The instrument package functions as a flight recorder that records all the parameters of interest during free-fall and penetration.

### TEST PROGRAM

The model anchors were tested at 330 m water depth at the Troll field in the North Sea in 2008. A total of 12 drop tests were performed varying the drop height above seabed from 15 to 75 m. As can be seen in Figure 2, the seabed entry velocity ranged from 13 to 15 m/s (29 to 33 miles/hour).

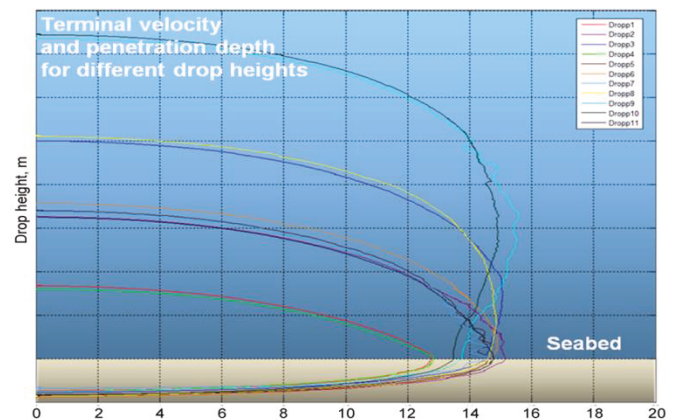

Fig.2 Free-fall distance versus Velocity, m/sec

### MOST SIGNIFICANT INFORMATION DERIVED

The tests showed that the stability of the anchor during free fall, and verticality after final penetration were repeatable and within acceptable limits. The tests confirmed penetration predictions and ultimate pull-out capacity. The average inclination of the anchor after penetration was less than 3°.

REFERENCE: Lieng and, Tjelta (1999)

## Example 23 (2009) - Pre-piling of foundations for offshore wind turbines

CATEGORY	MAIN OBJECTIVE	MAIN BENEFIT
Construction control	Monitor pile driving and final elevation of pile top	Reduced cost of construction

### BACKGROUND AND DESCRIPTION OF PROJECT

The current world-wide interest in renewable energy has resulted in an exponential growth in the number of planned and installed wind farms for generating electrical energy offshore. The European Commission stipulates that almost 9000 Offshore Wind Turbines (OWT's) will be in operation by year 2020 which corresponds to an installation rate of 2.5 OWT's per day. This has opened up another area where geotechnical instrumentation can play an important role.

At present the majority of the foundations for offshore wind parks consist of driven steel monopiles. However, as these installations move into deeper water (typical 25-50m) the bending stiffness of monopiles is not sufficient. Consequently, jackets or tripod foundations are required. Some wind farm projects may include hundreds of OWT's. Thus there is a need to simplify the installation process. One way to do this is to drive the piles in advance using a seabed template with pile guides, Figure 3. The larger (and more expensive) lifting vessels are then only required to deploy the jacket or tripods directly on the pre-piled foundations.

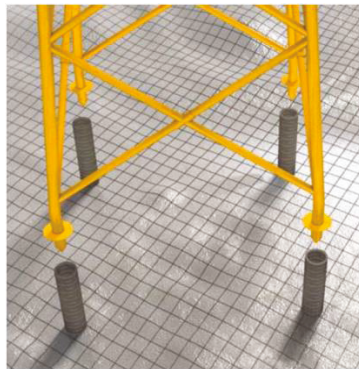

Fig. 1. Pre-piled jacket foundation

### FACTORS THAT INFLUENCED THE DESIGN OF THE MONITORING PROGRAM

The pre-piling method requires that the pile stick-up is monitored during pile driving and pile top elevation differences must be measured with high precision after all piles in the group are installed. These measurements will be crucial for leveling of the structure supporting the wind turbine.

The under-water conditions are usually very bad at offshore wind farm locations because of strong tides, poor visibility and obviously a lot of wind generated ocean waves. A major challenge is to establish a level horizontal reference for measurements in those conditions. In addition, the size of the piles (usually with 2.5 to 3 m diameter) makes measurements with millimeter precision demanding. Another challenge is to develop a monitoring system which will survive in the vicinity of a pile driving hammer.

### SCOPE OF INSTRUMENTATION

The development of pre-piling monitoring systems at NGI started in 2009 and has been improved in different stages. The

initial systems required diver or ROV assistance in placement and operation of the instruments. The system has subsequently been integrated with the piling template and is operated remotely from the surface without any subsea intervention. Obviously the durability of the system has been improved at the same time to eliminate the weak parts.

The key measurands are: Driven depth and inclination of the piles during driving, and final elevation and inclination of the pile tops.

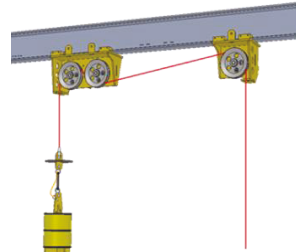

Fig. 2. Taut-wire based pile driving monitoring system

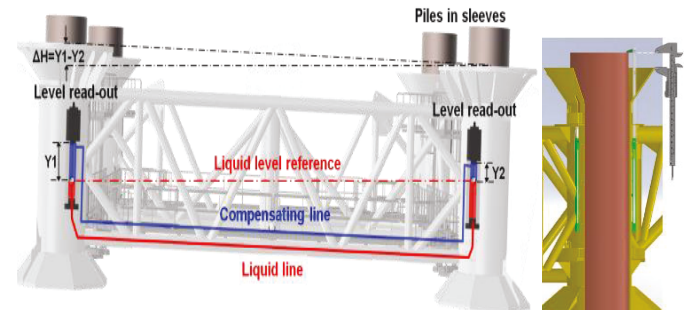

Fig. 3. Seabed template fitted with a liquid level system to monitor elevation difference of pile sleeves and caliper arms to measure the pile stick-up.

### MOST SIGNIFICANT INFORMATION DERIVED

The monitoring systems provide real-time data to control the pile driving to the specified depth. The pile elevation measurements and tilt angles are used to adapt the structure to fit the as-installed piles with a precision better than 10 mm. Spacers are commonly used to compensate for the differences in pile top elevations.

The measured data is a key element for the pre-piling installation method and has significantly reduced the costs for both offshore operations and the OWT structures themselves.

REFERENCE: Not published



## References

- Andersen, K.H., Dyvik, R.; Schröder, K.; Hansteen, O.E. Bysveen, S. [1993]. "Field test of anchors in clay. II: Predictions and interpretation". Journal of Geotechnical Engineering, ASCE. Vol. 119, No. 10, pp. 1532-1549. Also publ. in: Norwegian Geotechnical Institute, Oslo. Publication, 193.
- Cleave, R., Myrvoll, F. and Nåsund, R. (2009). Microseismic monitoring and early warning of geohazards along railway lines in Norway. *Int. Conference on Soil Mechanics and Geotechnical Engineering, 17*. Alexandria 2009. Proc. pp.2621-2624.
- DiBiagio, E., Bjerrum, L. [1957]. "International Conference on Soil Mechanics and Foundation Engineering, 4". London 1957. Proceedings, Vol. 2, pp. 196-202. Publikasjonskilde 2. Also publ. in: Norwegian Geotechnical Institute, Oslo. Publication, 026, pp. 31-37.
- DiBiagio, E. and Kjærnsli, B. [1961]. "Strut loads and related measurements on Contract 63a of the Oslo Subway". International Conference on Soil Mechanics and Foundation Engineering, 5. Paris 1961. Proceedings, Vol. 2. pp. 395-401. Also publ. in: Norwegian Geotechnical Institute. Publication, 45.
- DiBiagio, E.; Aas, G. [1967]. « Vane tests for investigation of anisotropy of undrained shear strength of clays ». Geotechnical Conference Oslo 1967 on Shear Strength Properties of Natural Soils and Rocks. Proceedings, Vol.1, pp. 19-26. Also publ. in: Norwegian Geotechnical Institute, Oslo. Publication, 076, 1968, pp. 7-14.
- DiBiagio, E. and Myrvoll, F. [1972]. "Full scale field tests of a slurry trench excavation in soft clay". European Conference on Soil Mechanics and Foundation Engineering, 5. Madrid 1972. Proceedings, Vol. 1, pp. 461-471. Also publ. in: Norwegian Geotechnical Institute. Publication, 91, pp. 39-49.
- DiBiagio, E. and Stenhamar, P. [1975]. "Prøvefylling til brud på bløt leire (Test fill to failure on soft clay)". Nordisk geotekniker møde København. Also publ. in: Norwegian Geotechnical Institute, Oslo. Publication 110, 1976, pp.9-14.
- DiBiagio, E., Myrvoll, F., Valstad, T. and Hansteen, H. [1982]. "Field instrumentation, observations and performance evaluations for the Svartevann dam". International Conference on Large Dams, 14. Rio de Janeiro 1982. Transactions, Vol. 1, pp. 789-826. Also publ. in: Norwegian Geotechnical Institute. Publication, 142.
- DiBiagio, E. and Høeg, K. [1983]. "Instrumentation and performance observations offshore". American Society of Civil Engineers. Conference on Geotechnical Practice in Offshore Engineering. Austin, Tex. 1983. Proceedings, New York, pp. 604-625. Also publ. in: Norwegian Geotechnical Institute. Publication, 155, 1985.
- Flaate, K.; Janbu, N. [1975]. "Soil exploration in a 500 m deep fjord, Western Norway". Marine Geotechnology, Vol. 1, No. 2, pp. 117-139.
- Gauer, P.; Issler, D.; Lied, K.; Kristensen, K.; Iwe, H.; Lied, E.; Rammer, L. & Schreiber, H. "On full-scale avalanche measurements at the Ryggfonn test site". Norway Cold Regions Science and Technology, 2007, 49, 39-53.
- Hagen, O.J.; Liestøl, O., Sollid, J.L., Wold, B. and Østrem G. [1993]. "Subglacial investigations at Bondhusbreen, Folgefonna, Norway". Norwegian Journal of Geography Vol. 47, 117-162 Oslo ISSN 0029-1951.
- Høeg, K. [1993]. "Asphaltic concrete cores for embankment dams". Norwegian Geotechnical Institute, Oslo, Norway ISBN 82-546-0163-1.
- Jamiolkowski, M., Carrier, W.D., Chandler, R.J., Hoeg, K., Swierczynski, W. and Wolski, W. [2010]. "1<sup>st</sup> Za-Chie-Moh Distinguished Lecture". The 17<sup>th</sup> Southeast Asian Geotechnical Conference, Taipei, Taiwan.
- Kjærnsli, B. and Sande, A. [1973]. "New waterproofing technique for Norwegian Dam". Norwegian Geotechnical Institute. Publication, 098.
- Lieng J.T., Tjelta T.I. [1999] "Deep Penetrating Anchor: Subsea deepwater anchor concept for floaters and other installations". Proc. 9<sup>th</sup> Int. Offshore and Polar Engr. Conf., pp. 613-619.
- Mikkelsen, P.E. and Green, G.E. [2003]. "Piezometers in fully grouted boreholes". VI International Symposium on Field Measurements in Geomechanics, Oslo, Norway. Proceedings, pp. 545-554. Balkema. ISBN 90 5809 6025.
- Myrvoll, F.; Bergstrand, B.; Glisic, B.; Enckell, M. [2009]. "Extended operational time for an old bridge in Sweden using instrumented integrity monitoring". Symposium on Strait Crossings, 5. Trondheim 2009. Proceedings, pp. 397-401.
- NGI [1974]. "Report 73060-2. Målte belastninger på bulkveggelement ved oppfylling med kalksalpeter".
- Nilsen, K.Y. and Lien, R. [1976]. "Description of a drainage gallery for stabilizing the left abutment of Muravatn Dam, Southern Norway". 12<sup>th</sup> International Conference on Large Dams, Mexico City. Transactions, Vol. 2, pp. 415-427. Also publ. in: Norwegian Geotechnical Institute. Publication, 115.
- Sparrevik, P. [2011]. "Extensio-Piezometer developed for Femern large scale tests". VIII International Symposium on Field Measurements in Geomechanics, Berlin, Germany.
- Strout and Tjelta (2005). In situ pore pressures: What is their significance and how can they be reliably measured? *Mar Pet Geol* 22(1-2):275-285E.
- Tjelta, T.I., Guttormsen, T.R. and Hermstad, J. [1986]. "Large scale penetration test at a deep water site". Offshore Technology Conference, 18. Houston, Texas 1986. Proceedings, Vol. 1, pp. 201-212.
- Tjelta, T.I. et al (2002). Ormen Lange Geoborings: Geological and Geotechnical Site Investigations in the Storegga Slide Area. *Symposium for Underwater Technology*.